

MEMS Digital Portable Horizontal Inclinometer (USB-C) From Serial DRI-1000



CE FC



TABLE OF CONTENTS

	0
1. VERSION CONTROL	3
2. INTRODUCTION	3
2.1. GENERAL DESCRIPTION	4
2.2. THEORY OF OPERATION	5
2.3. THE MEASUREMENT OF INCLINATION	7
3. CONFORMITY	8
4. MARKINGS	11
5. DELIVERY	12
5.1. PACKAGING	12
5.2. HANDLING	12
5.3. INSPECTION / FUNCTIONALITY CHECK READINGS	12
5.4. STORAGE	13
6. INCLINOMETER CASING INSTALLATION THEORY	13
6.1. BASELINE	13
6.2. DESIGN OF INCLINOMETER CASING	13
6.3. ZONE OF INFLUENCE	14
6.4. OPERATIONAL MODES	15
<i>i. Installation where both ends are accessible</i>	15
<i>ii. Installation where single end is accessible</i>	15
7. OPERATION	17
7.1. SYSTEM COMPONENTS	17
7.2. SYSTEM COMPONENT DESCRIPTIONS	19
7.3. BATTERY CHARGING	20
7.4. INSTALLING THE INCLINOMETER APPLICATION ON THE ASD	22
8. SYSTEM ASSEMBLY AND OPERATION	23
8.1. ASSEMBLING THE SYSTEM	23
9. USING INCLOPRO SOFTWARE APPLICATION (ANDROID)	38
9.1. RECORDING A SURVEY	38
9.2. VIEWING DATA	47
9.3. INITIAL / BASE SURVEYS	49
9.4. UPLOAD SELECTED SURVEY TO FTP	51
9.5. EMAIL/SAVE TO PHONE/BLUETOOTH	51
10. DATA HANDLING	52
10.1. DATA FORMAT	52
10.2. DATA REDUCTION	55
10.3. TEMPERATURE CONSIDERATIONS	58
11. MAINTENANCE	59
11.1. LUBRICATION AND CLEANING	59
11.2. STORAGE	60
11.3. CALIBRATION	60
12. TROUBLESHOOTING	61
12.1. PROBE	61

12.2.	ASD READOUT	62
12.3.	REEL AND CABLE	63
13.	SPARE PARTS	64
14.	RETURN OF GOODS	65
14.1.	RETURNS PROCEDURE	65
<i>iii.</i>	<i>Chargeable Service or Repairs</i>	65
<i>iv.</i>	<i>Warranty Claim</i>	65
14.2.	PACKAGING AND CARRIAGE	66
14.3.	TRANSPORT & STORAGE	66
15.	LIMITED WARRANTY	67

1. VERSION CONTROL

Version	Date	Author	Approved	Released
V1.0	Oct 2024	TB	TC	GC
V1.1	Jul 2025	CL	GC	CL

2. INTRODUCTION

This manual is intended for all users of the Horizontal Portable Inclinometer Systems manufactured by **Geosense®** and provides information on their operating principles, conventions, operation and maintenance.



**It is VITAL that all personnel responsible
for the use of the Portable Inclinometer
READ and UNDERSTAND
this manual, prior to working with the equipment**



2.1. General Description

The **Geosense® Portable Inclinometer** equipment is an environmentally sealed assembly that is used to accurately and reliably register changes of inclination within specialist inclinometer casing. The assembly comprises a probe connected to a graduated cable that is held on a cable reel. The reel is Bluetooth enabled for wireless connection to an Android Smart Device (ASD).

Inclinometer Casing can be installed or included in many types of structures and monitoring regimes. It can be within vertical, inclined or horizontal installations.

This manual is focused on the horizontal Inclinometer System

Common applications include the following:

- Embankment stability monitoring
- Settlement/heave profile monitoring
- Dam monitoring

Particular features of all **Geosense®** Portable Inclinometer Systems are:

- Reliable long-term performance
- Ruggedness; suitable for demanding environments
- Bluetooth, cable free interconnection
- High accuracy
- Digital output and full EMI shielding
- Designed with the user in mind

The **Geosense®** Inclinometer sensors are based upon Micro Electro Mechanical Systems technology (MEMS). The MEMS accelerometer sensors in the Inclinometer Probe are configured to measure changes in rotation (tilt or inclination). The probe contains two sensors mounted orthogonally to measure inclination in the 'A' axis direction (in line with the wheels) and rotation in the perpendicular, 'B' axis, direction.

Electronic circuitry within the probe interrogates its sensor and the corresponding output is converted from an Analogue to a Digital signal, making it particularly suitable for the demanding environments of geotechnical and civil engineering applications.

Geosense® Inclinometer probes carry 'onboard' calibration data so that probe / cable / reel / readout combinations are all interchangeable. Each element also has a unique serial number.

Portable inclinometer systems are commonly used where monitoring is to be infrequent or automated monitoring is too expensive. These systems are used to determine the change in inclination of the inclinometer casing at intervals along its length (commonly 0.5m or 2ft). This information is processed to generate a profile of the inclinometer casing, with respect to horizontal and subsequent profiles being compared with each other to detect changes.

2.2. Theory of Operation

Special tubes, commonly referred to as Casing or Access Tubes, are installed into or fixed onto the structure or formation to be monitored. (see **Geosense®** Inclinometer Casing Installation Manual).

Inclinometer casing is a specially machined ABS tube that has 4 equally spaced, parallel 'keyways' in its inner surface and a reference 'rib' on its outer surface. The inclinometer casing is designed to move with the structure/formation into which, or onto which it is fixed, if the structure changes.



Casing for the Horizontal Inclinometer MUST be installed so that one pair of keyways is VERTICAL



The Portable Inclinometer System is used to detect and quantify any changes in the 'shape' of the installed casing. For horizontal casing, changes in the vertical direction can be detected. The inclinometer probe, connected to its cable, is inserted into the inclinometer casing with its wheels located in the A+ / A- keyways (Figure 1: Schematic of inclinometer casing keyways).

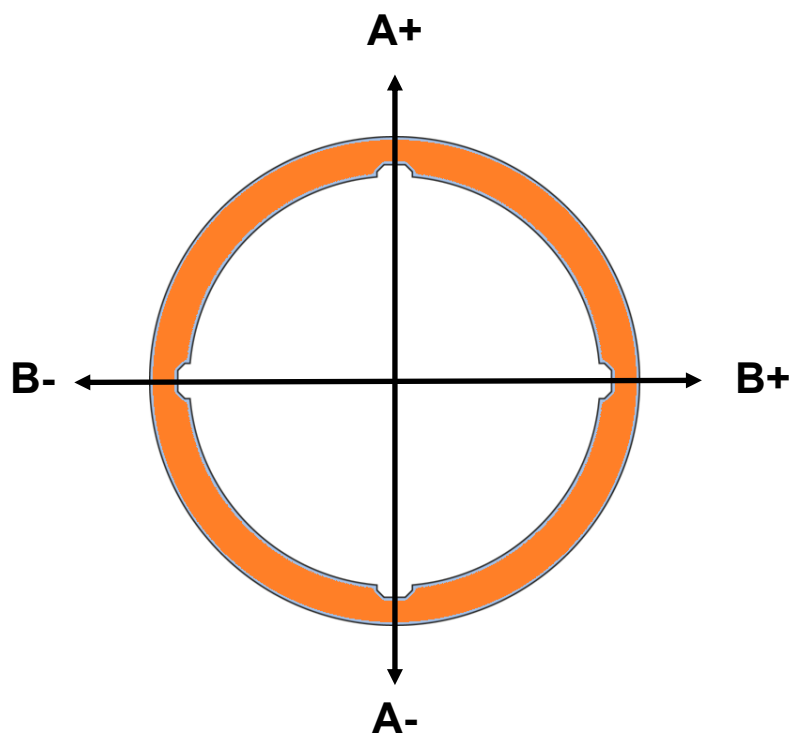

Figure 1: Schematic of inclinometer casing keyways

The **Geosense®** Digital Horizontal Inclinometer Probe houses a pair of extremely sensitive Micro Electro-Mechanical System (MEMS) **Tilt Sensors**. In the Horizontal probe, the 'A' axis is mounted with its 'Null' or 'Zero' output at 0° degrees from horizontal. The two sensors are mounted orthogonally so that they can measure the orientation of the probe along its length and the 'Roll' of the probe about its axis, simultaneously. The former is the primary measurement and referred to as the 'A' axis. The other axis is included for installation integrity purposes only and does not form part of the data calculations. It is referred to as the 'B' axis (see sketch).

The probe is attached to a highly robust and flexible support / signal cable that is, in turn, connected to a portable cable reel. The cable reel includes a Bluetooth communication module and a re-chargeable battery power supply. The cable is fitted with 'crimped' cable markers that securely identify 0.5 metre (or 2ft) intervals along its length.

The Cable Reel Bluetooth module is used to connect to an **Android Smart Device (ASD) or Ruggedized Android Mobile Phone** to the probe. The specially dedicated horizontal Inclinometer software on the ASD first connects to the reel modules and then to the probe at the end of the cable. Once connected the **ASD** displays the inclination of the probe in mm.

The displayed values represent the value of ' $L \sin \theta$ ' (Figure 2: $L \sin \theta$ and roll planes of measurement) in the 'A' direction and Degrees of 'Roll' in the 'B' direction.

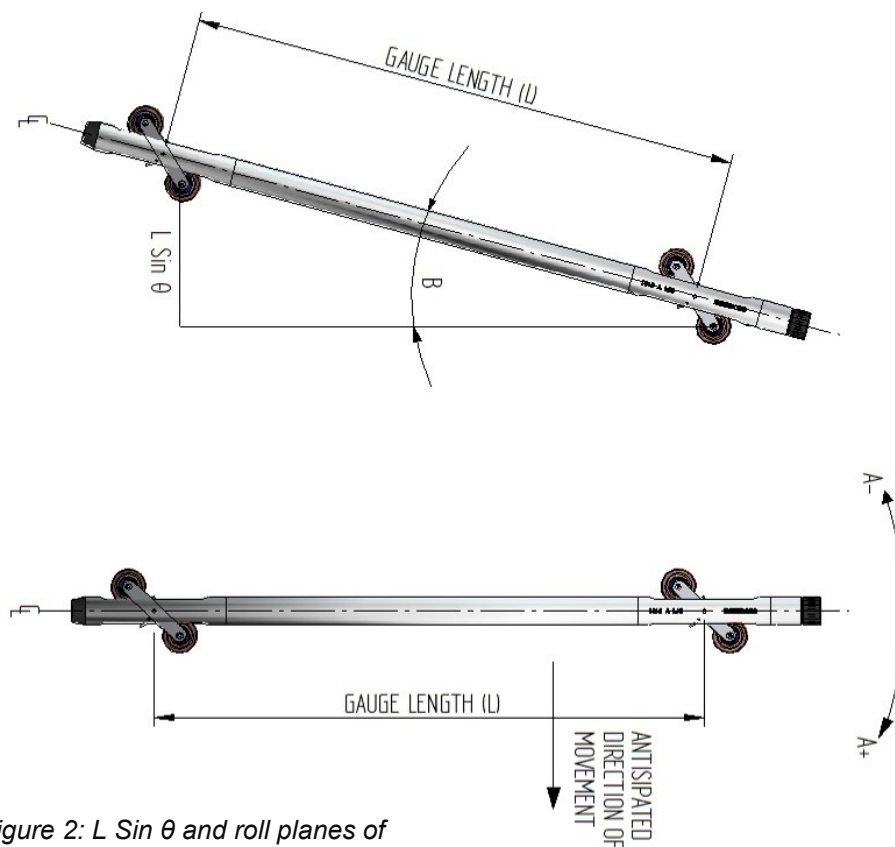

Figure 2: $L \sin \theta$ and roll planes of measurement

2.3. The Measurement of Inclination

To generate a profile of an installed inclinometer casing, a series of interconnected readings are recorded. The probe is orientated so that the fixed wheel is facing downwards and inserted into the casing with the sprung upper wheels in the corresponding upper groove. It is lowered to the far end of the casing and suspended on one of the metallic cable markings.

At the far end of the casing, with the probe suspended (not resting on the bottom), a reading is recorded. The probe is then lifted up by the distance equivalent to its 'gauge length' (see sketch) and another reading is taken. This process is repeated up the full length of the casing.

To minimise the issue of 'Human Error', Geosense® has introduced the option of 'Automatic Inclinometer Data Acquisition' into its proprietary software. This utilises the stability and accuracy of the sensors together with the intelligence of the ASD to allow the software to determine when the readings are considered stable, record them, instruct the user to move to the next reading elevation and sense when this has been carried out.

Essentially, the user has only to respond to a series of audible prompts, thereby almost removing the risk of errors caused by distraction, haste or miss-recording.

The uppermost wheel, denoted by the 'A+' on the probe, is the direction uppermost wheel.

A '+' change in the computed Displacement indicates a change in the inclination in the '+' direction.

In almost all cases, inclinometer surveys are conducted to record a profile from the base of the inclinometer tube towards the top, even if the movements are to be computed differently (from the 'Top Down'). Commonly, monitoring assumes the base of the tube is 'beyond the zone of expected movements', so movement data is computed accordingly. There are some circumstances where this assumption does not apply so movements are computed from the top downwards where the movement of the top of the tube can be determined by other measuring systems. Inclinometer surveys are almost NEVER conducted from the top towards the base.

Three surveys are normally conducted to establish the Base Data File (Initial Data). The values are either averaged to generate the Base Data or a 'Mean Data Set' is selected to represent the Base Data.

3. CONFORMITY

Simplified EU Declaration of Conformity for Radio Equipment Directive (2014/53/EU)

This information is provided for information purposes only and the accuracy of the text is not guaranteed and may be checked at in the relevant language version of 2014/53/EU published on the EU EUR-LEX website at <https://eur-lex.europa.eu/legal-content/EN/TXT/?uri=CELEX:32014L0053>

<p>Geosense Ltd tímto prohlašuje, že tento Portable MEMS Inclinometer je ve shodě se základními požadavky a dalšími příslušnými ustanoveními směrnice 2014/53/EU.</p>
<p>Undertegnede, Geosense Ltd erklærer herved, at følgende udstyr Portable MEMS Inclinometer overholder de væsentlige krav og øvrige relevante krav i direktiv 2014/53/EU.</p>
<p>Hiermit erkläre, Geosense Ltd dass sich das Gerät Portable MEMS Inclinometer in Übereinstimmung mit den grundlegenden Anforderungen und den übrigen einschlägigen Bestimmungen der Richtlinie 2014/53/EU befindet.</p>
<p>Käesolevaga kinnitab, Geosense Ltd seadme Portable MEMS Inclinometer vastavust direktiivi 2014/53/EL põhinõuetele ja nimetatud direktiivist tulenevatele teistele asjakohastele sätetele.</p>
<p>Hereby, Geosense Ltd declares that Portable MEMS Inclinometer is in compliance with the essential requirements and other relevant provisions of Directive 2014/53/EU.</p>
<p>Por medio de la presente Geosense Ltd declara que el Portable MEMS Inclinometer cumple con los requisitos esenciales y cualesquiera otras disposiciones aplicables o exigibles de la Directiva 2014/53/UE.</p>
<p>ΜΕ ΤΗΝ ΠΑΡΟΥΣΑ, Geosense Ltd ΔΗΛΩΝΕΙ ΟΤΙ Portable MEMS Inclinometer ΣΥΜΜΟΡΦΩΝΕΤΑΙ ΠΡΟΣ ΤΙΣ ΟΥΣΙΩΔΕΙΣ ΑΠΑΙΤΗΣΕΙΣ ΚΑΙ ΤΙΣ ΛΟΙΠΕΣ ΣΧΕΤΙΚΕΣ ΔΙΑΤΑΞΕΙΣ ΤΗΣ ΟΔΗΓΙΑΣ 2014/53/ΕΕ.</p>
<p>Par la présente, Geosense Ltd déclare que l'appareil Portable MEMS Inclinometer est conforme aux exigences essentielles et aux autres dispositions pertinentes de la directive 2014/53/UE.</p>
<p>Con la presente, Geosense Ltd dichiara che questo Portable MEMS Inclinometer è conforme ai requisiti essenziali ed alle altre disposizioni pertinenti stabilite dalla direttiva 2014/53/UE.</p>
<p>Ar šo Geosense Ltd deklarē, ka Portable MEMS Inclinometer atbilst Direktīvas 2014/53/ES būtiskajām prasībām un citiem ar to saistītajiem noteikumiem,</p>
<p>Šiuo Geosense Ltd deklaruoja, kad šis Portable MEMS Inclinometer atitinka esminius reikalavimus ir kitas 2014/53/ES Direktyvos nuostatas.</p>
<p>Hierbij verklaart, Geosense Ltd dat het toestel Portable MEMS Inclinometer in overeenstemming is met de essentiële eisen en de andere relevante bepalingen van richtlijn 2014/53/EU.</p>
<p>Hawnhekk, Geosense Ltd, jiddikjara li dan Portable MEMS Inclinometer jikkonforma mal-htigijiet essenzjali u ma provvedimenti oħrajn relevanti li hemm fid-Direttiva 2014/53/UE.</p>
<p>Alulírott, Geosense Ltd nyilatkozom, hogy a Portable MEMS Inclinometer megfelel a vonatkozó alapvető követelményeknek és az 2014/53/EU irányelv egyéb előírásainak.</p>

Simplified EU Declaration of Conformity for Radio Equipment Directive (2014/53/EU)

<p>Niniejszym <i>Geosense Ltd</i> oświadcza, że Portable MEMS Inclinometer jest zgodny z zasadniczymi wymogami oraz pozostałymi stosownymi postanowieniami Dyrektywy 2014/53/UE.</p>
<p><i>Geosense Ltd</i> declara que este Portable MEMS Inclinometer está conforme com os requisitos essenciais e outras disposições da Directiva 2014/53/UE.</p>
<p><i>Geosense Ltd</i> izjavlja, da je ta Portable MEMS Inclinometer v skladu z bistvenimi zahtevami in ostalimi relevantnimi določili direktive 2014/53/EU.</p>
<p><i>Geosense Ltd</i> týmto vyhlasuje, že Portable MEMS Inclinometer spĺňa základné požiadavky a všetky príslušné ustanovenia Smernice 2014/53/EU.</p>
<p><i>Geosense Ltd</i> vakuuttaa täten että Portable MEMS Inclinometer tyypinen laite on direktiivin 2014/53/EU oleellisten vaatimusten ja sitä koskevien direktiivin muiden ehtojen mukainen.</p>
<p>Härmed intygar <i>Geosense Ltd</i> att denna Portable MEMS Inclinometer står i överensstämmelse med de väsentliga egenskapskrav och övriga relevanta bestämmelser som framgår av direktiv 2014/53/EU.</p>
<p>Hér með lýsir <i>Geosense Ltd</i> yfir því að Portable MEMS Inclinometer er í samræmi við grunnkröfur og aðrar kröfur, sem gerðar eru í tilskipun 2014/53/EU.</p>
<p><i>Geosense Ltd</i> erklærer herved at utstyret Portable MEMS Inclinometer er i samsvar med de grunnleggende krav og øvrige relevante krav i direktiv 2014/53/EU.</p>
<p>Noi, <i>Geosense Ltd</i>, declarăm pe propria noastră răspundere că produsul Portable MEMS Inclinometer este în conformitate cu cerințele esențiale și celelalte prevederi aplicabile ale Directivei 2014/53/UE.</p>

FCC Compliance Statement (47 CFR § 15.19):

Unique Identifier: Geosense Ltd “Portable Inclinometer”

This device complies with part 15 of the FCC Rules. Operation is subject to the following conditions:

1. This device may not cause harmful interference, and
2. this device must accept any interference received, including interference that may cause undesired operation.

Responsible Party – U.S. Contact Information:

iCertifi
2445 NE Division St, Ste 202
Bend, Oregon 97703 USA

Tel: +1 866 885 4575
Internet: www.iCertifi.com

ISED Compliance Statement (RSS-Gen 8.4):

This device complies with Innovation, Science and Economic Development Canada’s license-exempt RSS(s). Operation is subject to the following two conditions:

1. This device may not cause interference, and
2. this device must accept any interference, including interference that may cause undesired operation of the device.

Responsible Party – Canada Contact Information:

Americas Compliance Consulting LLC dba iCertifi
380 Wellington Street, Tower B, 6th Floor, Suite 656,
London, Ontario, N6A 5B5, Canada

Tel: +1 866 885 4575
Internet: www.icertifi.com

4. MARKINGS

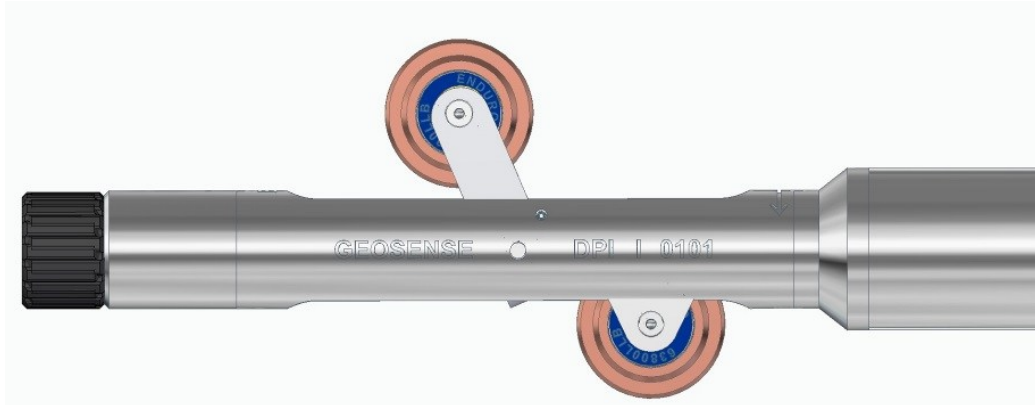

Figure 3: Geosense Inclinometer Probe Markings

All **Geosense® Digital MEMS Inclinometer systems** are labelled with the following information and each component carries a **unique** identification serial number that is included on the labels.

- Product group: MEMS Inclinometer system
- Product type: MEMS Inclinometer system
- Model: Horizontal
- Serial numbers: Probe: DPI H XXXX / Cable Reel: DRI XXXX
- CE mark
- FCC ID
- WEEE mark



5. DELIVERY

This section should be read by all users of equipment manufactured by **Geosense®**.

5.1. Packaging

Geosense® Inclinometers are packed for transportation to site. Packaging is suitably robust to allow normal handling by transportation companies. Inappropriate handling techniques may cause damage to the packaging and the enclosed equipment. The packaging should be carefully inspected upon delivery and any damage **MUST** be reported to both the transportation company and **Geosense®**.

5.2. Handling

Whilst they are robust devices, **Geosense®** Inclinometer systems are precision measuring instruments. They, and their associated equipment, should always be handled with care during transportation, storage and installation.

Once the shipment has been inspected (see 5.3), it is recommended that equipment remains in its original packaging for storage or onward transportation.

5.3. Inspection / Functionality Check Readings

It is important to check all the equipment in the shipment as soon as possible after taking delivery and well before installation is to be carried out. Check that all the components detailed on the documents are included in the shipment. Check that the equipment has not been physically damaged.

Geosense® Inclinometer probes are supplied with individual calibration sheets that include their serial numbers and these are shipped with the equipment.

Wherever possible, it is suggested that the Inclinometer systems should be functionally checked soon after arrival to ensure they have not been damaged during transportation. This is a basic 'out of the box' functional check. To carry out the check, follow the initial steps detailed in section 7 of this manual.

5.4. Storage

All equipment should be stored in an environment that is protected from direct sunlight and extreme heat. It is recommended that equipment be stored in a dry environment with caps in place, in an area free from rodents, as they have been known to damage cables and cases. Batteries should be charged regularly, even when the equipment is not in use, to maintain their capacity and life expectancy.

Temporary Storage

After reaching 0% charge, recharge the unit within 1-2 months to prevent permanent battery damage.

Long-Term Storage

If the probe is to be stored for long periods, a light coat of lubricant on the moving parts is advisable. Before storage, fully charge the reel and recharge the unit every 3-6 months to maintain battery health.

6. INCLINOMETER CASING INSTALLATION THEORY

6.1. Baseline

Prior to any survey taking place, the appropriate **Geosense®** Inclinator Casing will need to have been installed on site. The **Geosense®** Horizontal Inclinator system can be used to measure the profile of the casing in relation to a presumed fixed point.

If the system is being used to measure construction related movements in the heave or settlement process, it is good practice to set a baseline period before any monitoring for subsequent changes is undertaken. The baseline period may consist of different time periods based on site conditions.

Geosense® recommends that any site works have a suitable baseline period active before monitoring of settlement/heave using a horizontal system is used. This allows for seasonal and diurnal changes not related to the ongoing construction works to be understood and these can then be isolated from other movements in future review of the data.

A baseline period may not be relevant if the movement to be monitored is ongoing and not related to a specific activity on site that can be modally influenced.

6.2. Design of Inclinator Casing

Depending on the type and cause/source of any expected movement, it may be necessary to tailor installations to individual project needs. The below scenarios represent two such types of installation that may be used. Variations of these installations may also be used dependent on unique site situations.

6.3. Zone of Influence

The **Geosense**® Horizontal Inclinometer measures absolute angle, however the system as a whole is relative when referring to a measurement of displacement over a profile. This means that movement (displacement as a result of heave or settlement) in the vertical plane must be measured in relation to a fixed end of the system.



One end of a Horizontal Inclinometer installation MUST always be outside of the Zone of Influence for the expected heave or settlement event



Without a fixed end, it would not be known in which way either end of the profile had moved, as a heave at one end could also be construed as a settlement at the opposite end.

The end that is presumed with a high confidence to be outside of any zone of influence of settlement or heave is used as the “fixed” point. This can be either end of the installation, though it is recommended that this is the “Access End” as further precise level surveys can be conducted to confirm the stability of the reference end.

6.4. Operational Modes

The **Geosense® Portable Horizontal Inclinometer** is designed to be used on installations where either both ends, or only one end of the inclinometer casing is accessible.

i. Installation where both ends are accessible

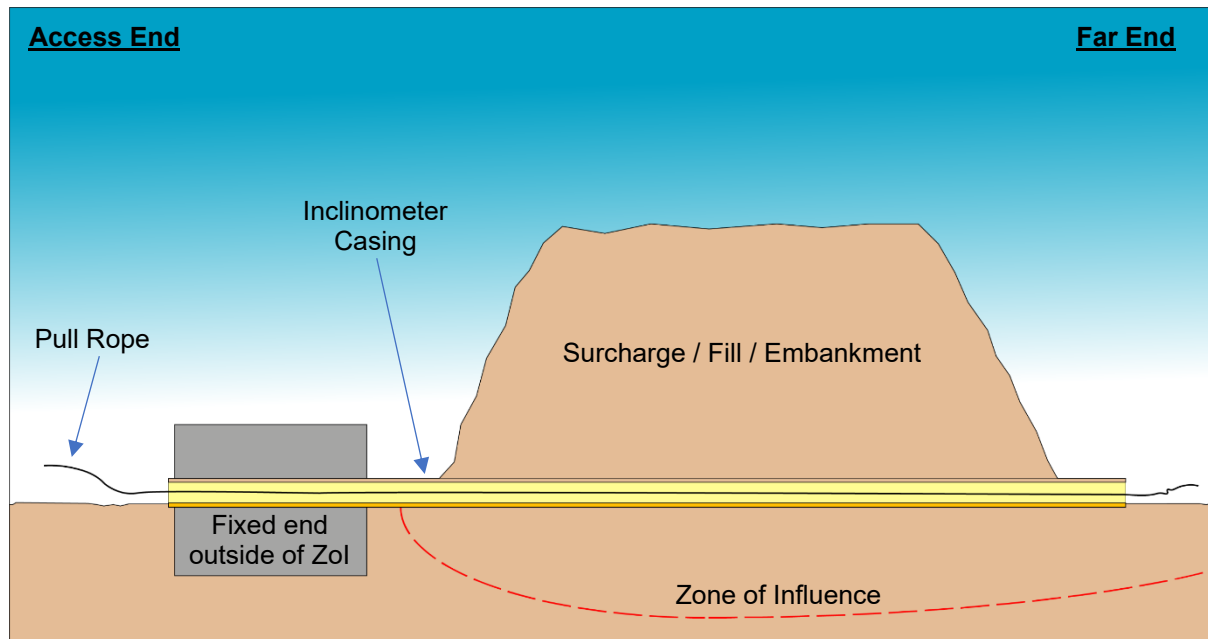

Figure 4: Inclinometer casing installation where both ends are accessible. A rope is run from one end to the other to allow a second person to pull from the opposite end

ii. Installation where single end is accessible

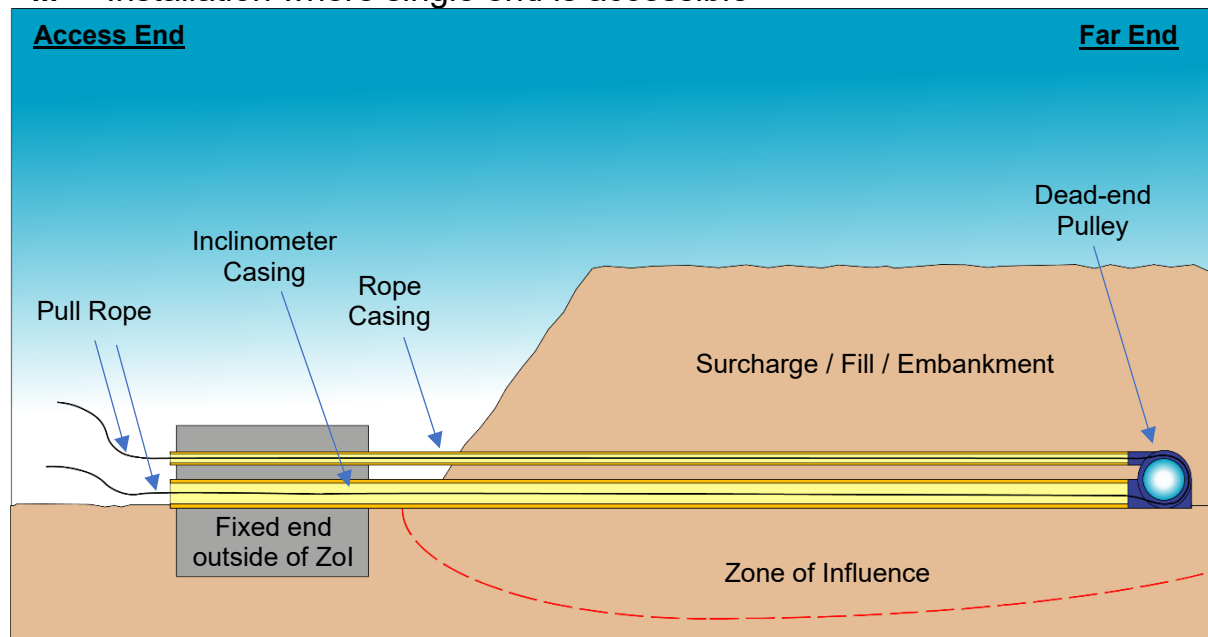

Figure 5: Inclinometer casing installation where only one end is accessible. A dead-end pulley is fitted along with a further access tube to allow for the probe to be pulled to the far end using a rope

Where one end is not accessible, **Geosense®** are able to supply a dead-end pulley which allows for the rope to be looped back and to the operator.



Figure 6: Dead-end pulley (pipe fittings may vary dependent on casing used)

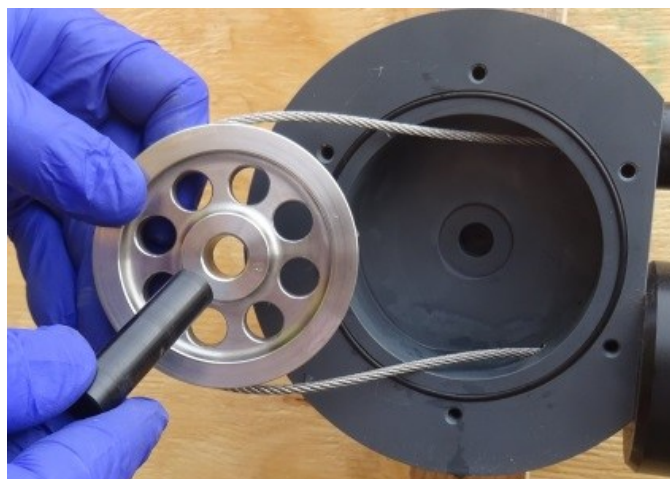

Figure 7: Dead-end pulley internal loop (for illustration of mechanism only, model may vary)

7. OPERATION

This section of the manual is intended for all users of portable **Geosense®** inclinometer equipment and is intended to provide guidance with respect to its use.

It must be remembered that no two installations will be the same and it is inevitable that some ‘fine tuning’ of the following procedures will be required to suit specific site conditions.

7.1. System Components

The **Geosense®** Horizontal Portable Inclinometer consists of two carry cases. One for the reel, and one for the sensor probe and ancillary equipment (Figure 9: Inclinometer Carry Case) and one for the reel and charger (Figure 8: Reel Carry Case)



Figure 9: Inclinometer Carry Case



Figure 8: Reel Carry Case

Illustrated below (Figure 10: Inclinometer Components) are the components of the Geosense® Inclinometer and Readout System

- A. INCLINOMETER PROBE**
- B. CABLE**
- C. CABLE REEL/ASD CHARGER and CABLE**
- D. ASD (ANDROID SMART DEVICE) and STYLUS**
- E. CABLE SUPPORTS**
- F. CAPS**

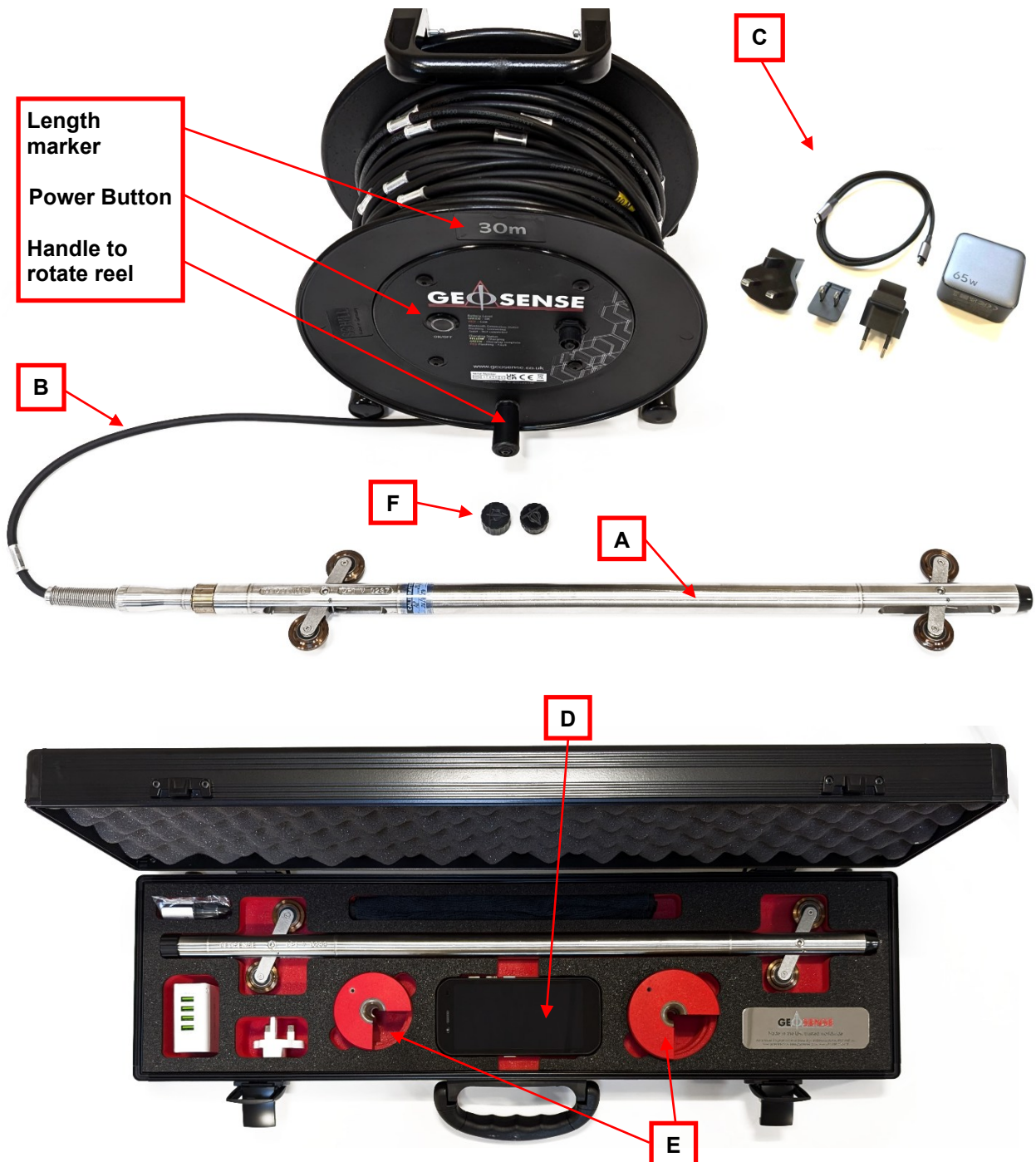

Figure 10: Inclinometer Components

7.2. System Component Descriptions

A. HORIZONTAL INCLINOMETER PROBE

The special probe in which the sensors and electronics are housed. Two pairs of wheelsets provide stability and maintain alignment. Each wheelset consists of one wheel which is fixed, and the other is sprung, to provide a tight fit within the casing grooves. Waterproof connector for attaching the cable.

B. CABLE

A rugged and flexible cable for electrical connection to the probe. Fitted with secure cable markers at 0.5 meter (or 2 ft) centres to accurately position the probe inside the inclinometer casing at defined and repeatable locations.

C. CABLE REEL with CHARGER

A convenient carrying facility for the graduated cable. Included in the reel body is the main inclinometer probe power supply and the Bluetooth communication module. The battery is charged by connecting the supplied charger to the charging socket on the face of the reel. Clips are fitted to the reel for convenient probe transportation.

D. ASD with CHARGER and STYLUS

A ruggedized, GSM enabled, Android device for reading, recording, displaying and transmitting the data from the inclinometer probe. Its internal battery is charged using the supplied USB charger / power supply.

E. CABLE SUPPORTS

For fitting into the top of all Geosense® Inclinometer casing (and the casing from most other manufactures), these are used to position the probe at a repeatable location within the casing.

F. CAPS

Protection for the electrical connections to be used when the probe is not connected to the reel.

G. CARRYING CASES

Anodised aluminium hard case for the inclinometer probe, readout and accessories. Hard wearing fabric case with shoulder strap for the cable reel and its charger.

H. SOFTWARE

The Geosense IncloPRO ASD application allows for data collection and basic review upon completion of a successful survey. Datasets can be graphically compared in the field and data can be stored either directly on the device or sent to the desired location. Further visualisation, interpretation and reporting software is recommended for post-processing of the data and is available upon request.

7.3. Battery Charging

Whilst the Reel and ASD have long battery lives, fully charging the equipment prior to visiting site is strongly recommended.

As with most handheld equipment, the ASD can be easily charged using most USB chargers and power banks. The reel requires a mains 100 - 250 VAC supply.

- 1) Remove the ASD, USB cable and charging brick from the carry case.
- 2) The charger is supplied with various mains plug adaptors. Select and fit the adaptor appropriate to the available mains electrical sockets.
- 3) Connect the charger to a mains electrical supply, switch it on and allow the ASD to charge fully.
- 4) The cable reel utilises the same charger as the ASD. Once the ASD is fully charged, use the same charger to charge the reel. (Figure 11)



Figure 11: Reel charger is contained in its own case, stored within the reel carry case

- 5) Remove the dust cap from the reel connector and fit the charger lead to the reel. (Figure 12: Charge Port - Inclinometer Reel)
- 6) Connect the charger to a mains electrical supply, switch it on and allow the readout to charge fully. (Indicated by a solid green light)



Figure 12: Charge Port - Inclinometer Reel

- 7) The reel has an indicator light and legend to illustrate the status of charging.

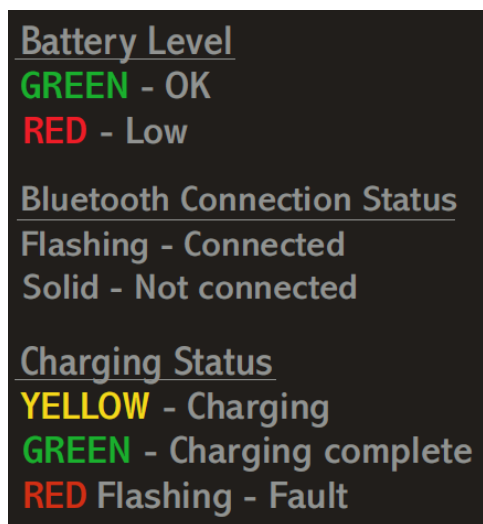

Figure 13: Reel charge legend

7.4. Installing the Inclinometer Application on the ASD

It is necessary to install the **Geosense®** software Inclinometer Application onto the ASD from the **Google® Play Store**. This will ensure the latest version is downloaded.

For this it will be necessary to establish an 'Identity' with **Google®** and establish a connection to the internet.

- 1) Start the ASD and tap on the **Google® Play Store**. This will be on the Home Screen.

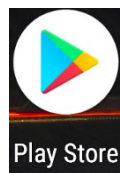

*Figure 14:
Google Play
Store on the
Home Screen
of the ASD*

- I. At this point, it will be necessary to either sign into a Google account or create an account.
- 2) Once logged in, search 'Google Play' for the Geosense Inclinometer Application named 'IncloPRO'.
 - I. Tap on the icon to open the App details.
 - II. Tap "Install".
 - III. Tap "Accept & download" after reviewing the list of permissions.
- 3) The IncloPRO icon will normally appear on the ASD home screen. If the icon does not appear, locate the icon in one of the App folders. (it can then be moved to the Home screen for convenience).
- 4) App permissions must now be set for the Android smart device (ASD) to connect to the reel. This can be accessed through the phone settings:

Settings → Apps & Notifications → App Info → Select 'IncloPRO' App
→ Permissions →
Allow Both Location and Storage Permissions

The App is now ready to connect to a reel.

8. SYSTEM ASSEMBLY AND OPERATION

8.1. Assembling the System

Most of the components of the Inclinator Readout System are contained within the hard carry case. Only the cable, reel and its charger are housed within the soft case.

- 5) Remove the probe from the hard case and remove the black cable connector cap (Item F - Figure 10: Inclinator Components)



- 6) Remove the cable reel from its case and remove the cable connector cover.



- 7) The **Geosense**® Horizontal Inclinometer has a connection at each end. This is so the probe can be rotated around the Z-axis to allow for the entry end to be changed between surveys.
- I. For the first survey run, the cable must be mated to the end of the probe marked with one ring.

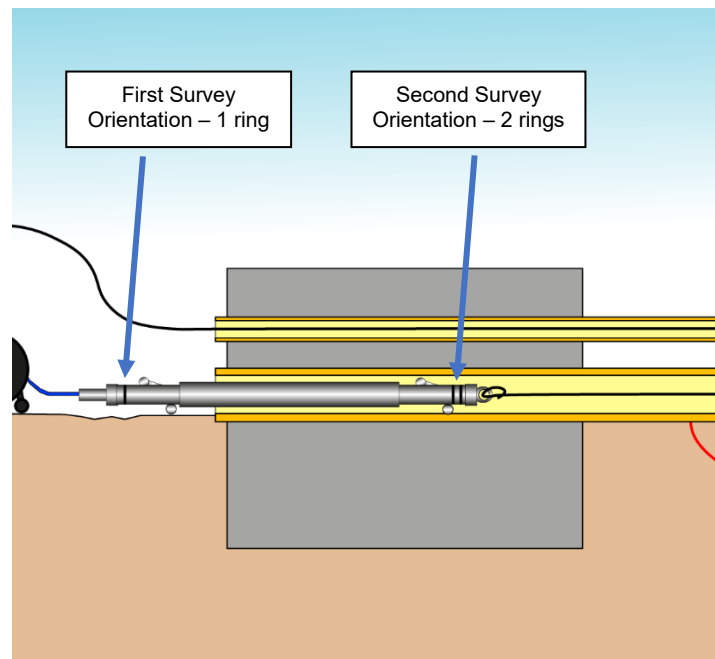

Figure 15: Demarcation of ends using rings

Note: for the second survey run, the probe will need to be rotated. This is included in a future step.

Taking note of the machined mating 'D' alignment in the plug and socket and the alignment markers, carefully connect the cable to the probe. Place the probe in a position where it can't fall or be damaged.



Do NOT attempt to mate the connectors if there is dirt or moisture present. Seals and connectors MUST be regularly serviced and maintained. Replacement seals are provided with the system along with silicone grease. If necessary, connectors can be cleaned with deionised/distilled water or electrical contact cleaner.



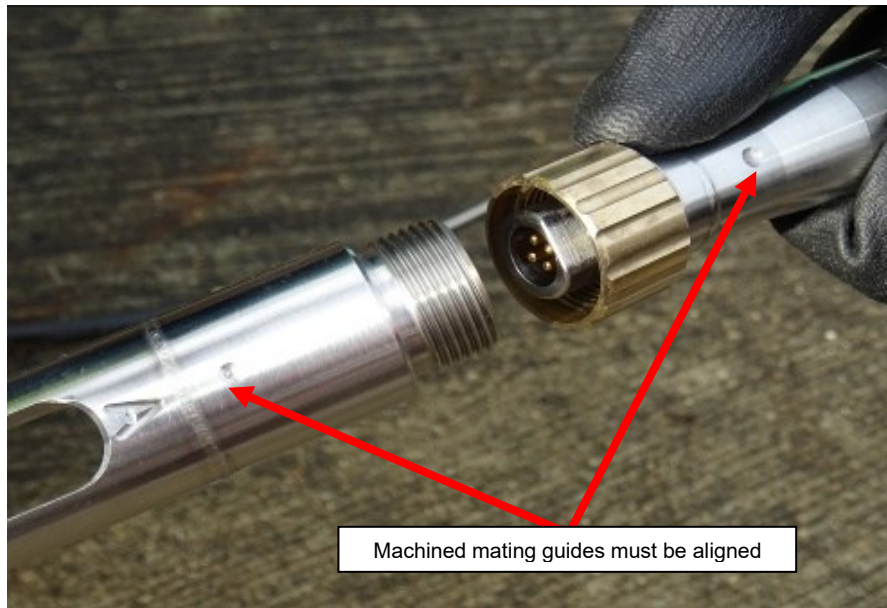

- 8) Remove the Android ASD from the hard case and turn it on. (For detailed ASD specific instructions see Section 9 later in this manual).

- 9) Press the ON/OFF button on the side of the reel, holding until its light switches on. This shows that the power is on with a GREEN light indicating an adequate battery level and a RED light indicating insufficient battery (the reel should be charged before monitoring is carried out).



- 10) On the ASD, check that the 'Bluetooth' symbol is showing in the top bar. (By default, it is set to turn on but if it is not, go to the ASD settings and turn it on).

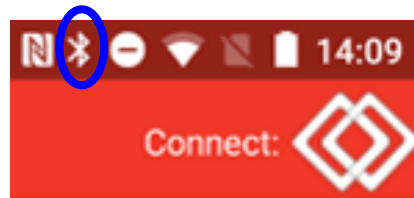

- 11) Open the **Geosense®** Inclinometer Application 'IncloPRO'. For detailed 'App' operating instructions, see Section 9.



Tap the 'Connections' icon on the lower menu bar to open the Connections page.

A list of 'Paired Reels' will be presented. Check that the serial number of the reel to be used is included in the list. If not, tap the 'SEARCH FOR NEW REEL' bar.

A list of all local Bluetooth devices will be presented on the screen. Scroll through the list to locate the serial number of the Reel being used and tap on it to activate the pairing operation.

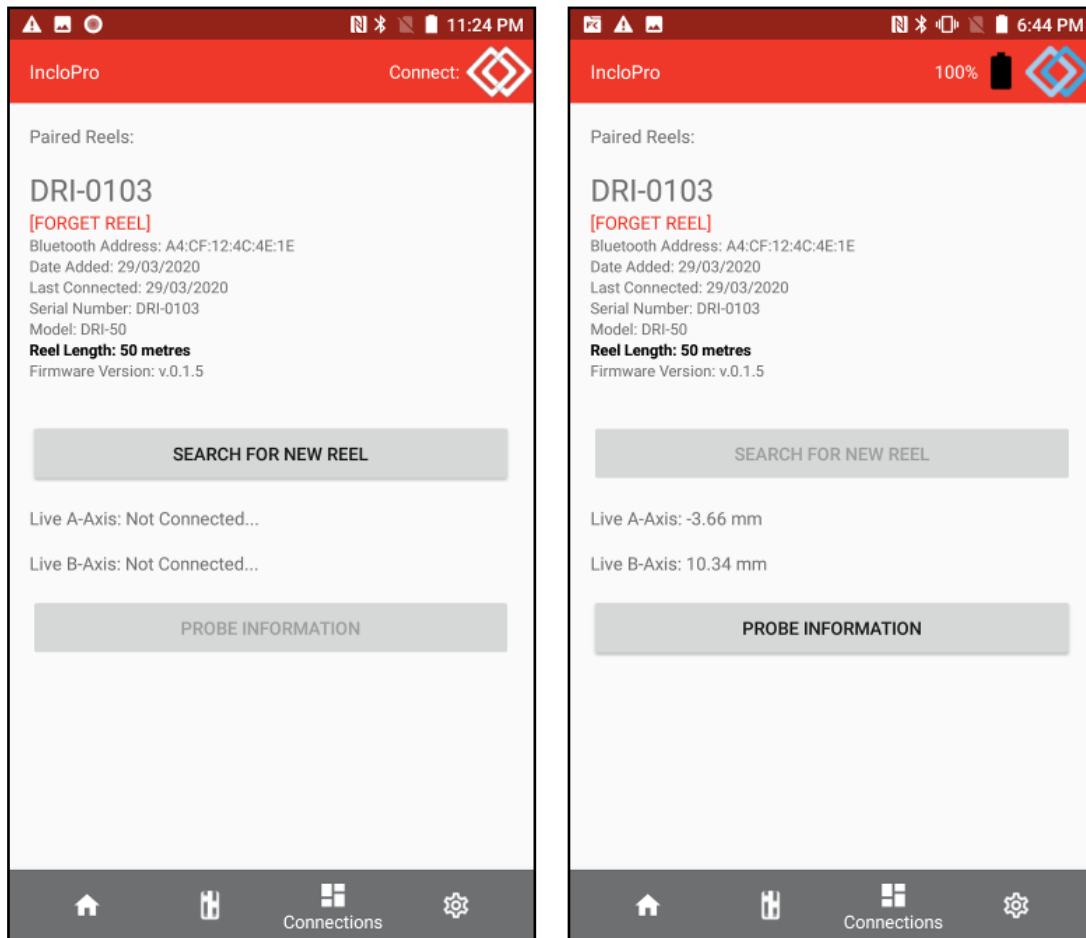

Figure 16: Paired Reels Screen

- 12) When using the App for the first time, it will be necessary to search for the Reel to carry out this pairing operation. Once paired, the ASD memorises the configuration. (Figure 16: Paired Reels Screen)
- 13) Tap the “Connect” icon to check the Bluetooth connection. When connected, the connection is confirmed by displaying the Reel battery condition and the Reel temperature.



Figure 17: Reel Temperature, Reel Battery Percentage and Reel Connection Icon

In addition, Live probe readings are shown on the screen, above the PROBE INFORMATION bar. (Figure 16: Paired Reels Screen)

- 14)** Tap the 'Connect' icon again if you wish to break the Bluetooth connection. It should return to an 'all white' colour. **(If you are about to conduct a survey, leave the reel connected for now).**

- 15)** It is good practice to make sure the connection to the probe is good and the readings are relatively stable before the probe is inserted into the casing. This ensures that if there is a loose connection due to the connectors not mating properly, it can be detected before the probe enters the installation.

16) Remove the cover from the inclinometer access tube if there is one. (A secure cover is strongly recommended to stop any foreign objects or animals entering the pipe work. Horizontal installations if not sealed can house rodents which can deposit nesting material that will block the access casing)

Prior to any horizontal survey, the pull rope must have been installed within the inclinometer casing. NEVER remove a rope from an installation as it may be very difficult or impossible to replace it.



Identify both ends of the pull rope that is installed within the inclinometer casing. You will need a length of slack at the access end from the inclinometer casing (red arrow, Figure 18: Single end installation) of equal length to the inclinometer casing.

- I. If using a single ended installation, make sure both ends of the rope are visible and there is adequate slack at the end of both ends. A length of the rope equal to the length of the inclinometer casing will need to be pulled through the inclinometer casing.

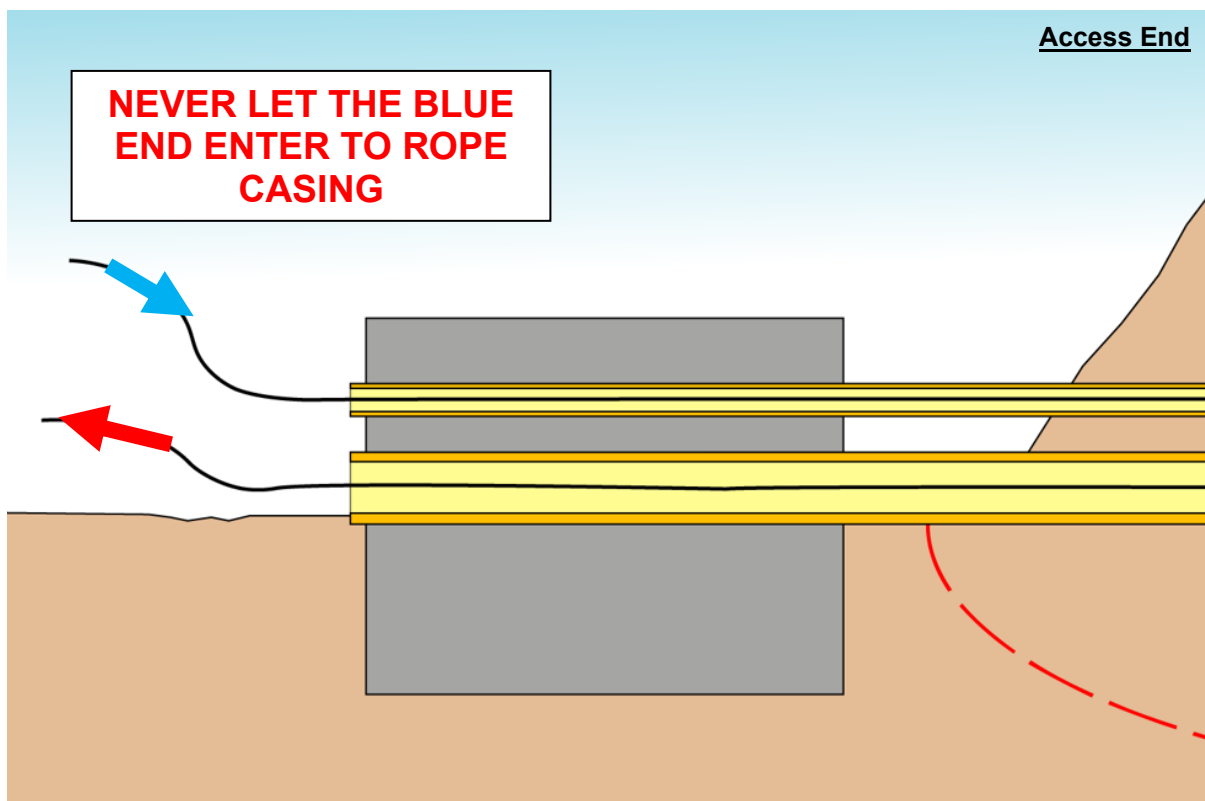
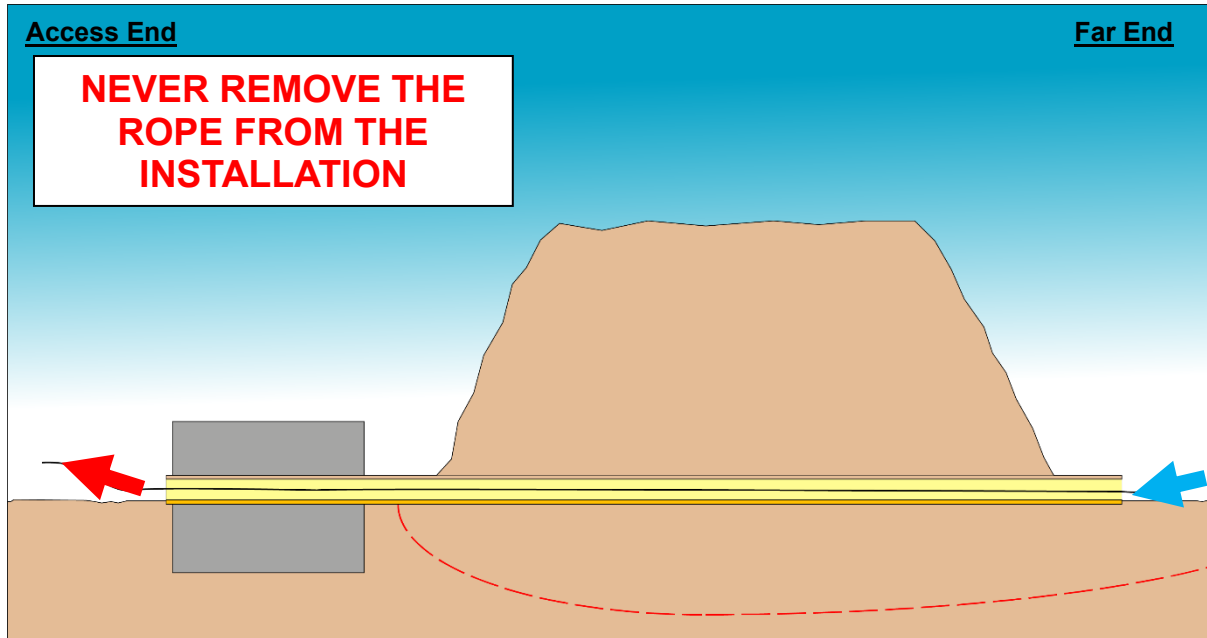
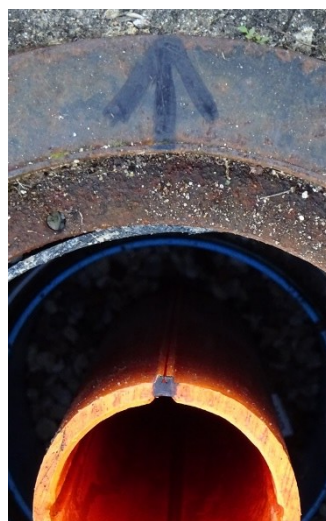

Figure 18: Single end installation

- II. If using a double ended installation, pull the rope through to the access end from the far end. Have someone stationed at the far end to make sure the loose end of the rope does not enter the installation. If you lose the end of the rope it may be difficult or impossible to recover.



- 17) Identify the 'Primary' axis keyways in the tube, sometimes referred to as the 'A' or 'A+/A-' axis. For horizontal applications this MUST be the vertical axis. Only this pair of keyways need to be used.



18) Release the brake screw on the side of the Cable Reel.



- 19) Attach the dead-end pulley rope that is present inside of the inclinometer casing to the base end of the inclinometer probe. (For the first survey run, attach the eyelet to the end of the probe marked by 2 rings).



Figure 19: Eyelet cap attached to second end of the probe, marked with 2 rings in later models (a 2 is shown in this model)



It is CRITICAL that the pulley rope is FIRMLY ATTACHED and cannot fowl or become detached. Loss of this attachment may render the installation INOPERABLE. Do not leave a long tail on the knot as this can fowl probe



- 20) The dead-end pulley assembly of the inclinometer casing installation must be used to keep tension on the probe at all times. Allowing the rope to go slack within the casing may result in rare cases with the probe wheels becoming fowled and jamming.

21) With tension applied to the “tension-end” of the rope, insert the Inclinometer probe into the casing in the vertical keyways. The fixed wheels must run at the base, with the sprung wheels gently slotted into the start of the access casing by hand.

Single end access

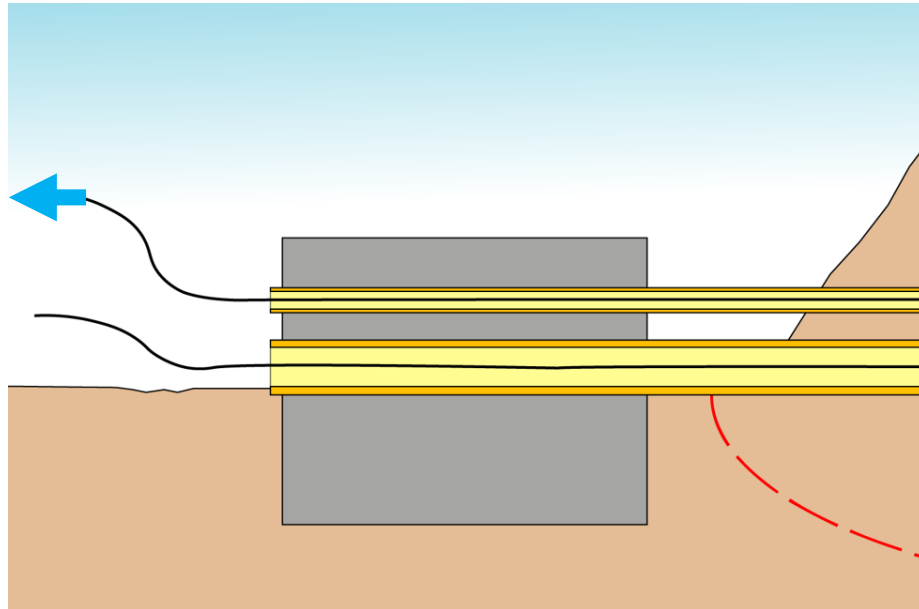

Figure 20: Tension applied to “tension-end” of the rope

Double end access

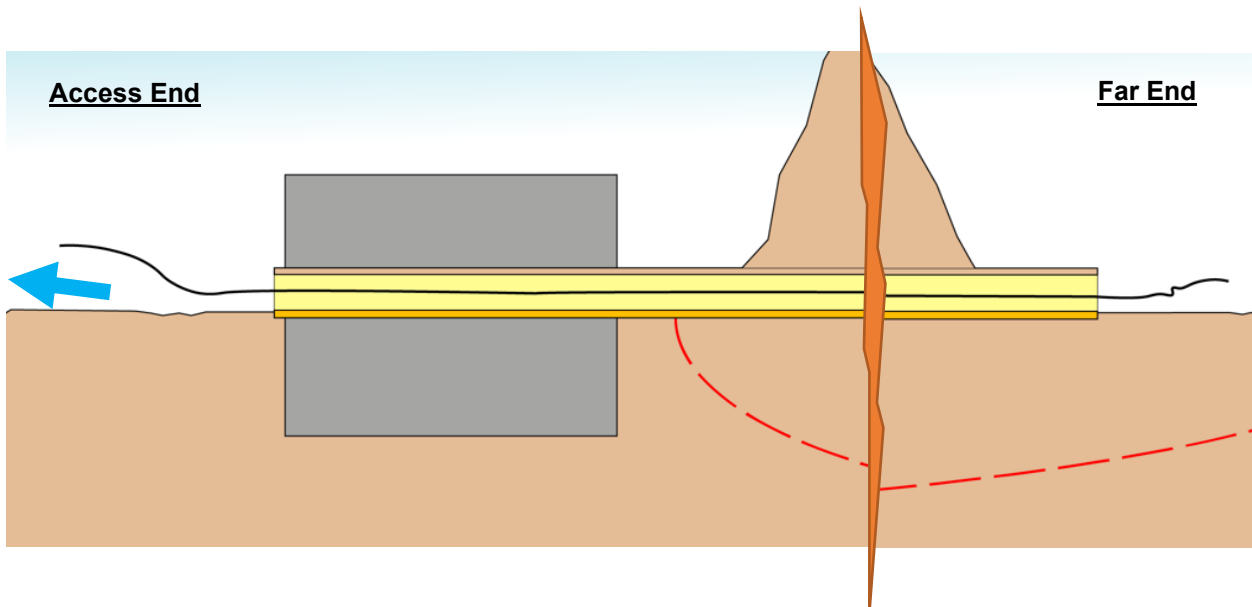

Figure 21: Tension applied to “tension-end” of the rope, located at the far end of the installation, by a second operator

- 22)** With tension applied to the “tension-end” of the rope, insert the Inclinometer probe into the casing, with the wheels engaged into the keyways. The sprung wheels will always be at the top, with the fixed set at the base.



Figure 22: Inclinometer probe inserted into access casing.

23) Once the probe has entered the casing fully, the probe should be pulled to the far end using the “tension-end” of the rope for the start of the survey.

The survey should always be started from the far end.

You must always start the survey from the same position (i.e. the depth marker of the cable must always be the same for an install at the start of a survey). Tension must be kept on the inclinometer reel. Do not allow either the pull rope or the inclinometer cable to go slack at any time.

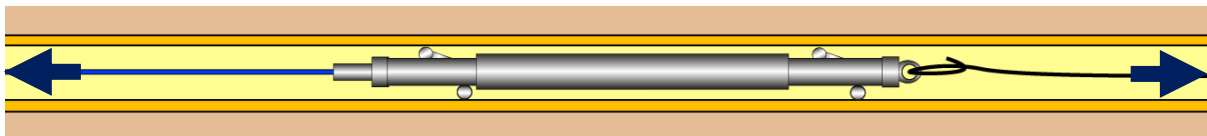

Figure 23: Inclinometer sent to the far end within casing with tension applied to both the pull rope and the cable to stop either of them going slack

24) Place the cable gate onto the access end.



Figure 24: Cable gate fitted onto the access end of the casing

- 25)** Using the rope and the cable, move the Inclinometer Probe to the far end of the casing, stopping when the ferrule marking the correct distance (depth if compared to the vertical system) is reached. Keep tension on the rope and cable at all times to avoid any slack.
- 26)** Set the cable ferrule into the cable gate (with tension applied to the “tension end” of the pull rope) at the depth you need to start your survey from.
- 27)** Apply a very light tension to the rope, to keep the ferrule in place within the cable gate. The tension should be constant otherwise the probe will be shaken, and the reading will not be accurate. (The software will not allow a reading to be taken if the probe is not stable. If this occurs, slightly reduce the tension on the rope, being mindful that there may be slight movement in the probe if the casing slopes downhill in either direction). It may take a few minutes for the temperature of the probe to stabilise, it is good practice to allow a period of time for the temperature of the system to equilibrate if the probe has for example been kept in a warm car and the outside temperature is cold.
- 28)** Take the reading using the IncloPRO software. Linking the Android device to the reel can be found in section 8.1 with details of the software use in 9. USING INCLOPRO SOFTWARE APPLICATION (ANDROID).
- 29)** Once the reading has been taken using the software, the probe can be moved up to the next ferrule and the process repeated until the probe reaches the access end of the casing.

30) Once you reach the top/access end with the probe, the survey needs to be repeated, with the probe rotated 180 degrees around the Z-Axis.

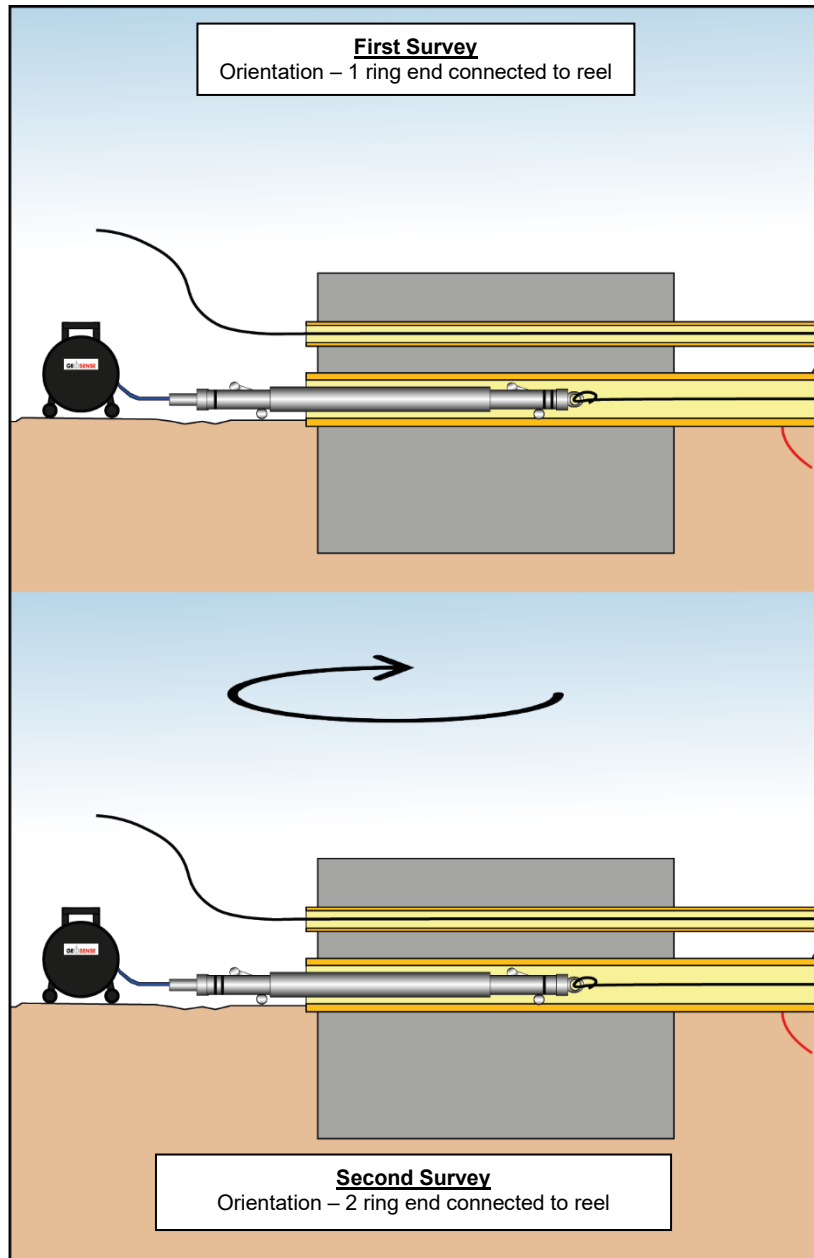

Figure 25: Probe rotated around Z-axis 180 degrees between surveys.

9. USING INCLOPRO SOFTWARE APPLICATION (ANDROID)

9.1. Recording a Survey

The following steps detail how the readings can be taken with the IncloPRO Android application. Section 8. SYSTEM ASSEMBLY AND OPERATION must be followed for the operation of the survey.

The methodology may include steps already taken in the previous section. If these have been completed already, please skip to the following step.

- 1) Open the IncloPRO Android application.

If not done so already and the probe is within the casing – switch the reel on and connect to the app as detailed in section 8.

- 2) Navigate to the “Borehole” screen with the button at the base of the app.
- 3) Select the site and borehole you wish to conduct a survey for.

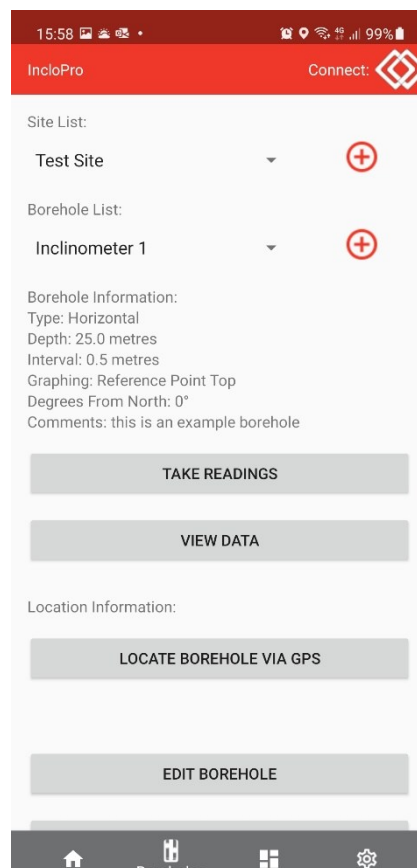

Figure 26: "Boreholes" screen showing the selected site and borehole (survey location)

- I. If this is the first time a site has been visited for a survey, add the site/project that the Inclinometer survey is to be conducted on.
 - i. Press the “+” symbol to the right and below the “Site List” and add the name of your site or project.
 - ii. Press the “+” symbol to the right and below the “Borehole List” and add the boreholes (survey locations) for the project along with ancillary information.

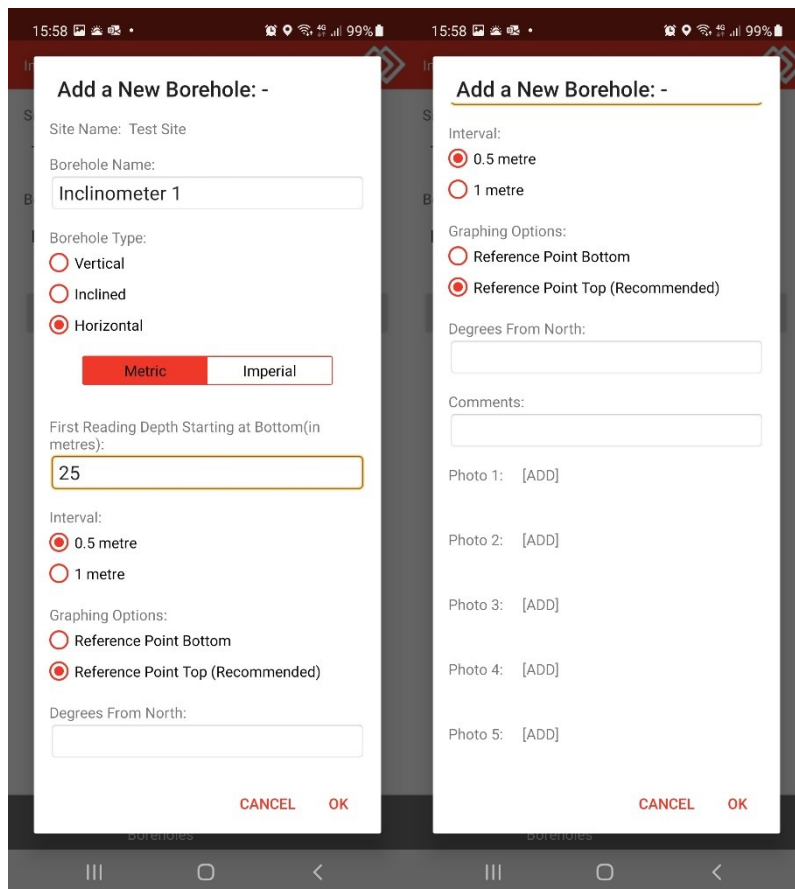

Figure 27: Adding borehole screens

Table 1: Borehole configuration settings

Borehole Settings	Description
Borehole Name	Text entry for the name of the borehole the survey is being conducted on
Borehole Type	The orientation of the survey. Different probes are required for different orientations
First Reading Depth	The depth/distance from the access/top of the installation in metres that the first reading will be taken from
Interval	The survey interval – this will depend on the probe length.
Graphing Options	The presumed fixed point for the survey movement to be display with reference to.
Degrees from North	Mainly used for Inclined and Vertical systems, a text entry that stores information purely for reference at a later date
Comments	A text entry for any comments
Photos	Allows for storage of photos with reference to the borehole for future identification or information purposes

- 4) When you are ready to begin the survey, select the “TAKE READINGS” button

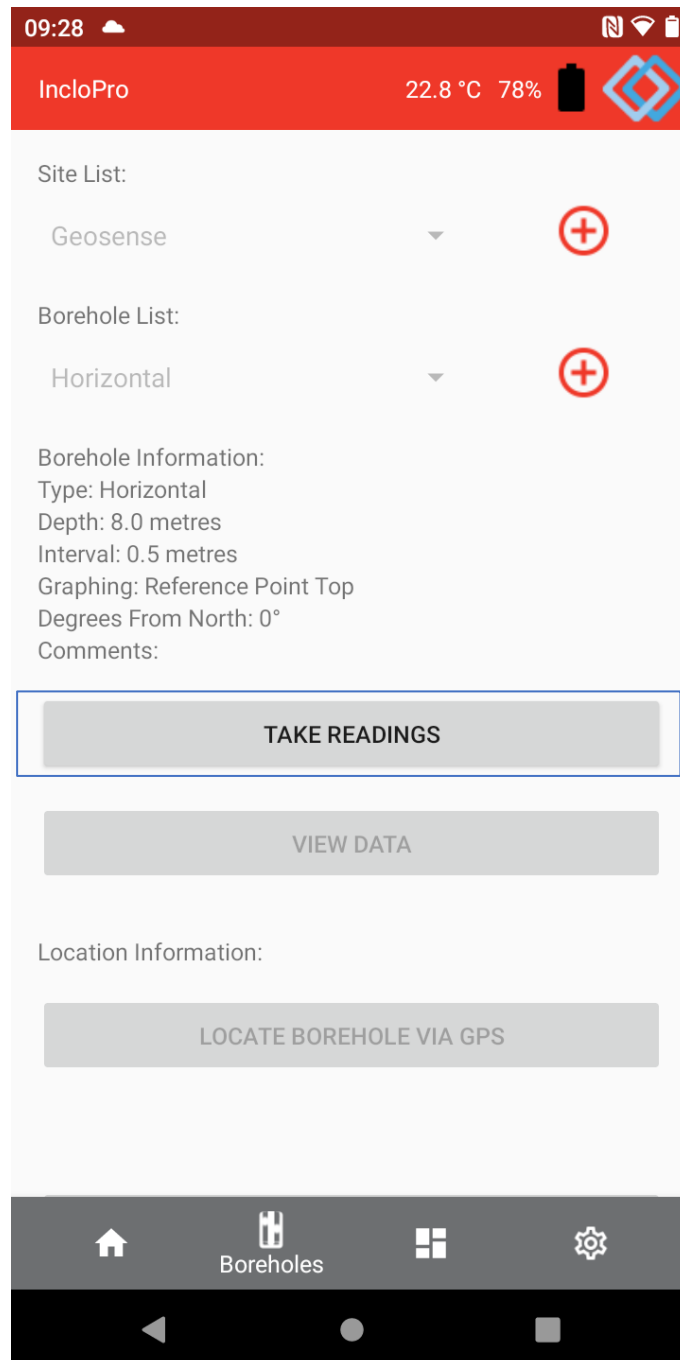

Figure 28: Take readings

- 5) With the probe inserted to the far end of the casing and at the first depth to be recorded, wait for the probe temperature to stabilise

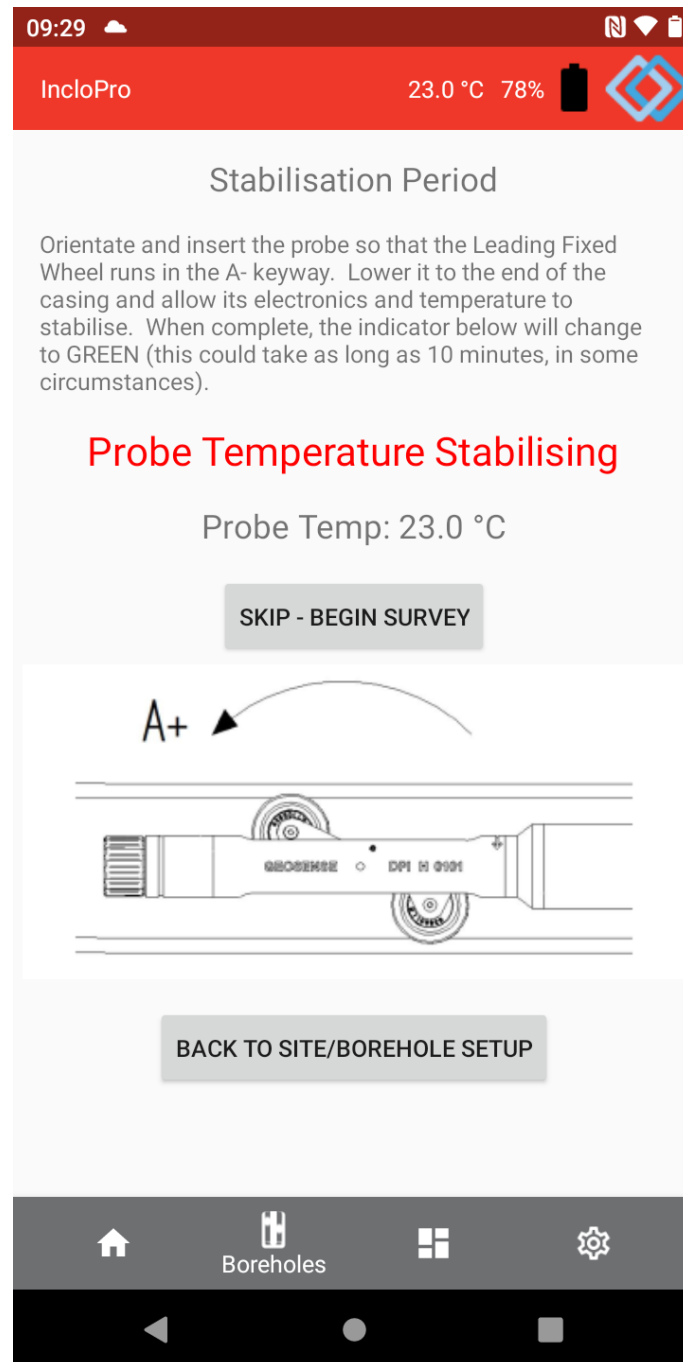

Figure 29: Probe stabilising

- 6) Once the probe has stabilised, you will be notified, and the survey can begin by pressing “Begin Survey”.

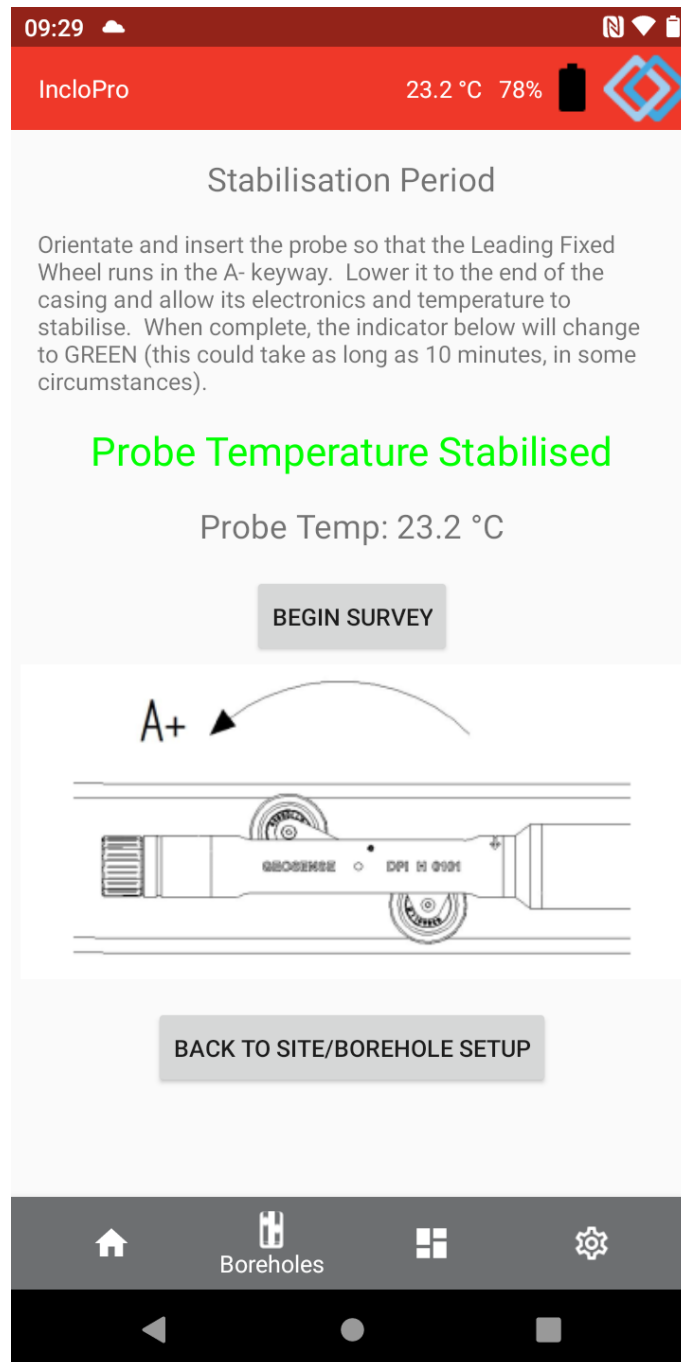

Figure 30: Begin survey once the probe has stabilised

- 7) Once the survey begins, the first reading will show the live readings, the depth will be the furthest point from the access end, as set in the borehole information in the app. Make sure that the depth marked on the cable matches the depth shown in the app for each reading. The probe will detect when it is stable. If the readings are not stable the app will signify this. When ready, press **“ACCEPT READING”**.

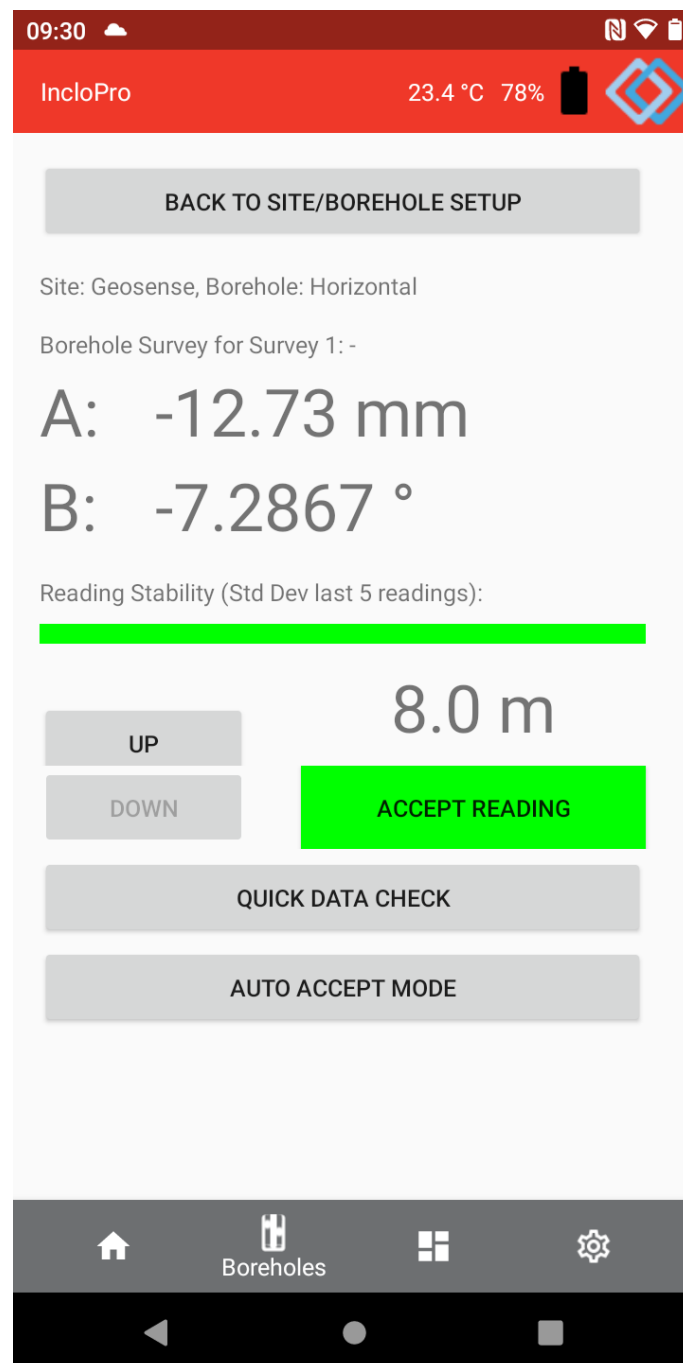

Figure 31: Live readings and "ACCEPT READING" button,

- 1) Once the reading has been accepted, the app will move to the next depth (in this example, 7.5m as the probe is 0.5m long (as set in the borehole setup)). The probe will always move through three stages regardless of whether it is in manual or auto mode.
 - I. Waiting for probe to settle
 - II. Probe settled taking reading
 - III. Reading taken move the probe



Figure 32: Stages of taking a reading

- 2) If the user wishes, the system can be put in “**AUTO ACCEPT MODE**”. This will automatically take the reading when the probe has stabilised, and all the user has to do is move the probe once the app signifies it is safe to do so. “**AUTO ACCEPT MODE**” can be entered by pressing the button on screen.
- 3) When in “**AUTO ACCEPT MODE**” the probe will detect when it has been moved to the next incremental point and will then continue to take the next reading when stable.

If the probe stability remains RED for a continuous 60 seconds, the App will revert back to Manual mode as it deems the site / position to be subjected to too much vibration (noisy).

Auto Accept Mode can be started or cancelled at any depth, even midway through a survey.

- 4) Once the probe reaches the top/access end of the installation, follow the on-screen instructions in the app and rotate the probe 180 degrees as per Figure 25: Probe rotated around Z-axis 180 degrees between surveys.

- 5) At any time, the “**QUICK DATA CHECK**” can be activated, but “**AUTO ACCEPT MODE**” must be cancelled first.

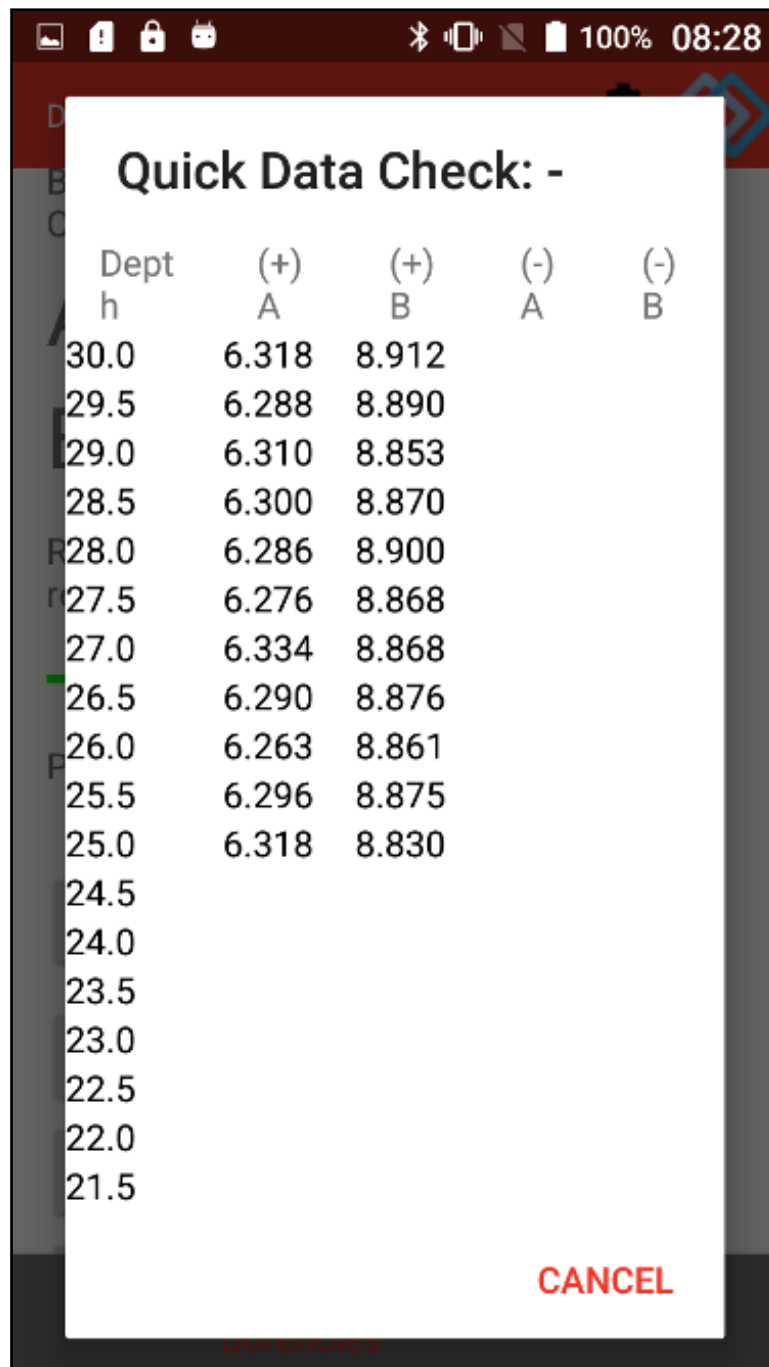

Figure 33: Quick data check screen

- 6) Use the “**QUICK DATA CHECK**” button to view the readings stored in memory, so far, at any point in the survey. (perhaps to check the current position in the borehole survey). “**CANCEL**” will return to the “**TAKE READING**” screen.

If an error is detected, the depth can be changed to retake a reading from another position, by using the UP / DOWN buttons.

9.2. Viewing Data

All completed surveys can be accessed from the “VIEW DATA” screen, located within the Borehole selection screen.

All completed surveys, for a selected borehole, are listed on this screen. Up to 3 surveys can be flagged as ‘Base Readings’ using the “SET BASE SURVEYS” button.

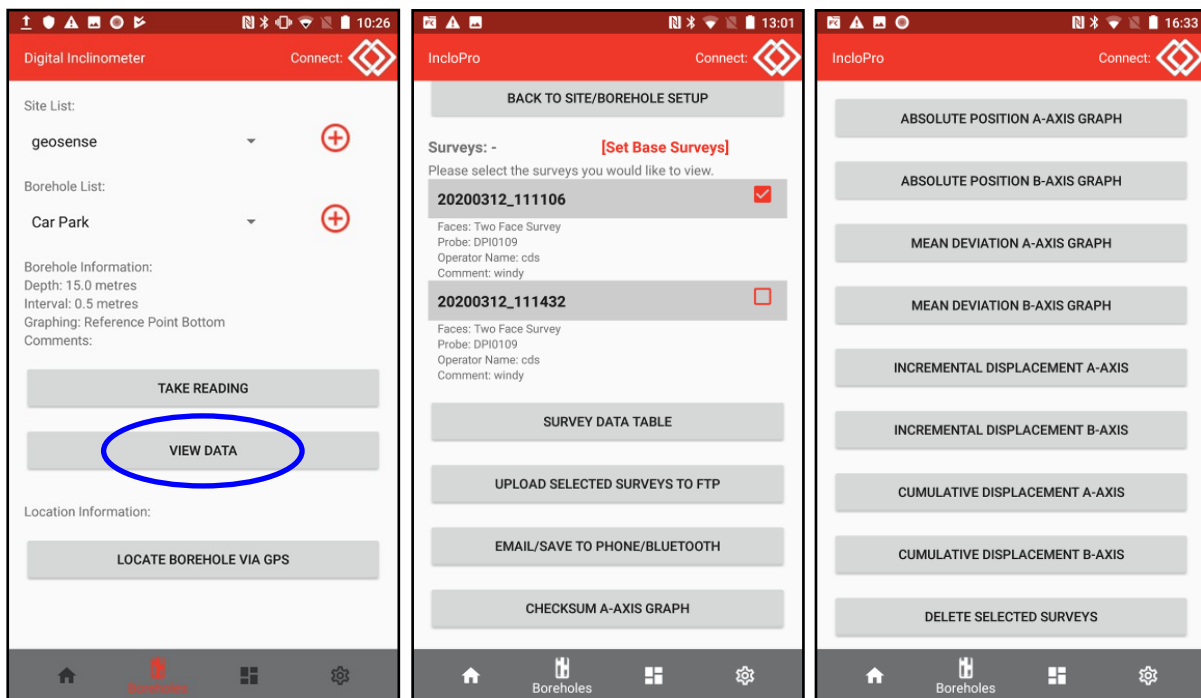

Figure 34: View data screens

Table 2: View Data - Options available to the user

View Settings	Description
Survey Data Table	On screen display of the survey data (one survey selected at a time)
Upload Selected Survey to FTP	Creates an output file (in select output format) and uses FTP details entered into the settings menu to FTP the file for further analysis.
Email/Save to Phone/Bluetooth	Creates an output file (in selected output format) ready to be saved onto the phone or emailed. A default email address can be entered into the settings menu to speed up this process.
Checksum A/B Axis Graph	On screen graph showing checksum for each axis.
Absolute One-Face Graph	Only available for one face surveys
Absolute Position A/B Axis Graph	On screen graph showing absolute position for each axis.
Mean Deviation A/B Axis Graph	On screen graph showing mean deviation for each axis.
Incremental Displacement A/B Axis Graph	On screen graph showing incremental displacement across each axis (requires at least 1 base survey to be selected for calculations).
Cumulative Displacement A/B Axis Graph	On screen graph showing cumulative displacement across each axis (requires at least 1 base survey to be flagged for calculations).
Delete Selected Surveys	Allows for surveys to be deleted

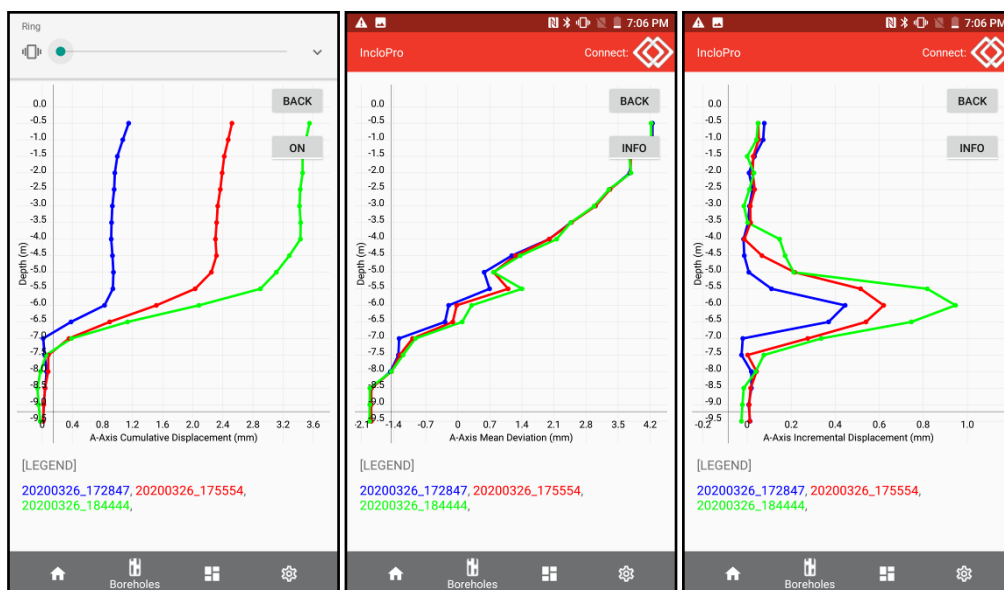

Figure 35: Generic examples of displayed data

9.3. Initial / Base Surveys

It is common to carry out three sets of Initial Readings to form the Base Data file. Therefore, IncloPRO can use one, two or three sets of data to form the Base Data file, to which subsequent readings are compared.

The App averages the readings at each depth, so it is important that only 'GOOD' data is used in the Base Data Reference.

Readings can be viewed and graphed to assess their quality and suitability for the Base Data file.

To select data set(s) for use as the Base Data:

- 1) tap the **“SET BASE SURVEYS”** at the top of the Surveys list.

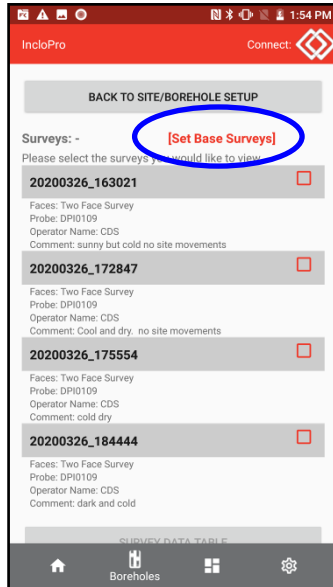

- 2) Select the suitable files and tap **“OK”**.

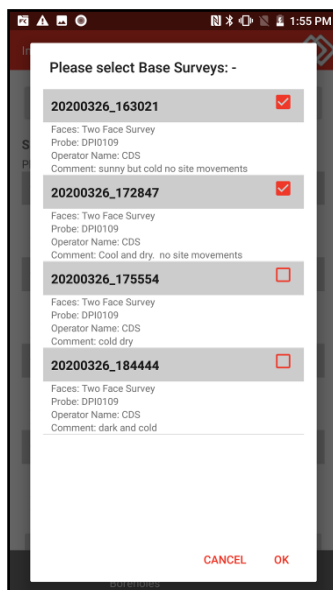

This selection is stored on the ASD (Android Smart Device) so that it is not necessary to make this selection each time the data is viewed.

9.4. Upload Selected Survey to FTP

Where data is to be sent directly to a remote server, this option creates a file in the selected output format (CSV or RPP) and uses FTP details entered into the settings menu, to send the transmission. A mobile data connection (SIM Card) or Wi-Fi network connection is required.

9.5. Email/Save to Phone/Bluetooth

This option creates output files for each data set selected. The file name structure will be:

[site name]-[borehole name]-[date]_[time].csv

Or

[site name]-[borehole name]-[date]_[time].rpp

The App asks where the file(s) are to be stored or sent. An email client must be configured on the phone to send the data via email. A default email address can be entered into the settings menu, to speed up this process.

First select the files to be transferred, then tap the **“EMAIL/SAVE TO PHONE/BLUETOOTH”** option. This will bring up the transfer option window on the ASD.

To email the files, select the mail client and follow their particular procedures.

To save the file locally, select **“Save to Device”** (wording may vary with Android build), which will lead to the save location window.

Select 'Internal Storage' to save to a particular location on the device or 'Downloads' for directly to that location (other options are available).

To save the file(s) for later transfer by Bluetooth or USB cable, its suggested that a folder is created in the 'root directory' in the internal storage of the ASD.

10. DATA HANDLING

10.1. Data Format

Once an inclinometer survey has been completed, the readings are saved to the database on the ASD. The data can be viewed on the ASD using the Application, as described earlier in section 9.2 of this manual.

For detailed analysis, either automated or manual, the recorded values need to be transferred to another device. This can be done by USB / email / Bluetooth or other means.

If '.csv' format is selected, the exported data file format is ASCII, making it commonly accessible via many software packages, and small in size.

Geosense® has worked closely with '**Deep Excavations Inc**', to enable PC based data handling via their '**Site Master**' Inclinometer Data Presentation Software package. Data exported from the ASD can be simply and easily imported into Site Master for clear and effective computation and presentation. For details refer to **Geosense® Ltd Sales or Support departments**.

The structure of an exported file is detailed below. It comprises a header that includes details of the site, borehole, equipment, survey and operator, followed by strings of data. Below is an example of the information included in the header and its 'comma separated' layout (as opened in a Text Editor).

```
Site Name: Budleigh Salterton,,,,,,,,,,,,,,,,,,,,,,,,,,,,,  
Borehole Name: BH 1,,,,,,,,,,,,,,,,,,,,,,,,,,,,,,,,,,,,,  
Borehole Depth: 9.5 metres,,,,,,,,,,,,,,,,,,,,,,,,,,,,,  
Interval: 0.5m,,,,,,,,,,,,,,,,,,,,,,,,,,,,,,,,,,,,,  
Degrees From North: 210,,,,,,,,,,,,,,,,,,,,,,,,,,,,,  
Latitude: 50.630998, Longitude: -3.320214,,,,,,,,,,,,,  
Operator Name: CDS,,,,,,,,,,,,,,,,,,,,,,,,,,,,,,,,,,,,,  
Probe Serial Number: DPI0109,,,,,,,,,,,,,,,,,,,,,  
Reel Serial Number: 103,,,,,,,,,,,,,,,,,,,,,,,,,,,,,  
Survey Date: 20200326_163021,,,,,,,,,,,,,  
Survey Comment: sunny but cold no site movements,,,,,,,,,
```

Opened in a spreadsheet, each comma should be set to delineate a column so the header information would be presented as follows:

Table 3: Manually entered borehole information – these details are commonly entered manually at the setup stages, and automatically populated when the data is exported. The Longitude and Latitude would be generated in the App on the ASD, by an active GPS facility

Table 3: Manually entered borehole information

Site Name: Budleigh Salterton	
Borehole Name: BH 1	
Borehole Depth: 9.5 metres	
Interval: 0.5m	
Degrees From North: 210	
Latitude: 50.630998	Longitude: -3.320214
Operator Name: CDS	
Probe Serial Number: DPI0109	
Reel Serial Number: 103	
Survey Date: 20200326_163021	
Survey Comment: sunny but cold no site movements	

The following highlighted line of the file identifies the sequence of the variable values.

	A	B	C	D	
1	Site Name: Budleigh Salterton				
2	Borehole Name: BH 1				
3	Borehole Depth: 9.5 metres				
4	Interval: 0.5m				
5	Degrees From North: 210				
6	Latitude: 50.630998	Longitude: -3.320214			
7	Operator Name: CDS				
8	Probe Serial Number: DPI0109				
9	Reel Serial Number: 103				
10	Survey Date: 20200326_163021				
11	Survey Comment: sunny but cold no site movements				
12	ID	DEPTH_METRES	A_POSITIVE_SINX	B_POSITIVE_SINX	
13		19	0.5	0.0083666	0.0019453
14		18	1	0.0083852	0.0019631
15		17	1.5	0.0074967	0.0019666
16		16	2	0.0075014	0.0019636
17		15	2.5	0.0066257	0.0020389

Figure 36: Sequence of variable value columns

Table 4: Variable value descriptions

ID	reading sequence (top of the tube = highest No.)
DEPTH_METRES	depth of a readings (cable marker value) in metres
A_POSITIVE_SINX	Sine of Angle of probe inclination for A+
B_POSITIVE_SINX	Sine of Angle of probe inclination for B+
A_POSITIVE_MM	Probe inclination in mm for A+ (mm per probe length)
B_NEGATIVE_SINX	Sine of Angle of probe inclination for B-
A_NEGATIVE_MM	Probe inclination in mm for A- (mm per probe length)
B_NEGATIVE_MM	Probe inclination in mm for B- (mm per probe length)
POSITIVE_TEMP	Temperature of the probe electronics for the '+' readings
NEGATIVE_TEMP	Temperature of the probe electronics for the '-' readings

The following figure (Figure 37: Format of raw .csv file format from export) shows the formatting of a typical raw .csv file export.

```
ID, DEPTH_METRES, A_POSITIVE_SINX, B_POSITIVE_SINX, A_POSITIVE_MM, B_POSITIVE_MM, etc
19,0.5,0.0083666,0.0019453,4.1833,0.97265,-0.0083284,0.0216397,-4.1642,10.8198, 17.246,17.532
18,1,0.0083852,0.0019631,4.1926,0.98155,-0.0083313,0.021654,-4.16565,10.827,17.253,17.545
17,1.5,0.0074967,0.0019666,3.74835,0.9833,-0.0074857,0.0215836,-3.74285,10.7918,17.251,17.538
16,2,0.0075014,0.0019636,3.7507,0.9818,-0.0074974,0.0215763,-3.7487,10.7881,17.260,17.545
etc, etc, etc
```

Figure 37: Format of raw .csv file format from export

10.2. Data Reduction

Data reduction and presentation can also be carried out using a standard spreadsheet. The following is a guide on how each value would be calculated.

The first stage is to import the '.csv' data file, ensuring that a comma is identified as the 'delineator' for the columns.

Once the data is imported, and assuming that the site name is in cell A1, expand the columns to show all the values they contain.

	A	B	E	F	I	J	
1	Site Name: Budleigh Salterton						
2	Borehole Name: BH 1						
3	Borehole Depth: 9.5 metres						
4	Interval: 0.5m						
5	Degrees From North: 210						
6	Latitude: 50.630998	Longitude: -3.320214					
7	Operator Name: CDS						
8	Probe Serial Number: DPI0109						
9	Reel Serial Number: 103						
10	Survey Date: 20200326_163021						
11	Survey Comment: sunny but cold						
12	ID	DEPTH_METRES	A_POSITIVE_MM	B_POSITIVE_MM	A_NEGATIVE_MM	B_NEGATIVE_MM	
13		19	0.5	4.1833	0.97265	-4.1642	10.8198
14		18	1	4.1926	0.98155	-4.16565	10.827
15		17	1.5	3.74835	0.9833	-3.74285	10.7918
16		16	2	3.7507	0.9818	-3.7487	10.7881
17		15	2.5	3.31285	1.01945	-3.26705	10.7821
18		14	3	2.97485	1.0234	-3.01115	10.775
19		13	3.5	2.4673	1.0566	-2.46255	10.7358
20		12	4	1.99455	1.04885	-2.0264	10.7139

Figure 38: Data reduction

To simplify the spreadsheet, it is recommended to hide all the columns EXCEPT A, B, E, F, I and J. Therefore, the only visible columns will be the Header Data and column ID, together with Depth and readings for A+, B+, A- and B-.

The 0.5m reading for the A+ direction should be in cell E13

Since inclinometer are commonly installed to quantify changes in a structure, it is necessary to establish the reference set of data to which subsequent data can be compared. The reference data set is often called the Base (or Initial) Data.

Commonly accepted 'Best Practice' is to record 3 sets of data from an inclinometer tube, soon after installation, to generate the Base Data. These should be recorded, one after the other, in the same conditions to verify the precise profile of the installed inclinometer tube. Following a review of the recorded files, either a single file can be selected as the 'Base Data File', being the mean of the sets, or an average data set can be created from 2 or all 3 of the surveys.

Table 5: Commonly computed values

Computed Value	Description
Mean Deviation	<p>These values are the actual inclinations of the probe, in mm, at each elevation (where Deviation implies offset from Horizontal over the length of the probe wheelbase). For any particular depth, the values are calculated by the following equations:</p> $\text{Mean A} = ((\text{Reading A+}) - (\text{Reading A-}))/2$ $\text{Mean B} = ((\text{Reading B+}) - (\text{Reading B-}))/2$
Checksum	<p>The checksums are a measure of the integrity of the data set. They compare the '+' and '-' values at each depth and compute the difference.</p> <p>The difference represents slight misalignments and imbalances in the electronics and mechanics of the probe. These are quite normal and the reason for recording both '+' and '-' values is to remove these differences. Geosense® calculate the Checksums using the following equation:</p> $\text{Checksum A} = (\text{Reading A+}) + (\text{Reading A-})$ $\text{Checksum B} = (\text{Reading B+}) + (\text{Reading B-})$ <p>Checksums should be reasonably small and consistent over the length of the survey.</p>
Absolute	<p>When plotted these values represent the actual shape of the inclinometer tube and provide an understanding of the verticality and any 'wander' of the installation. Computation for both the A and B directions will confirm the location of the far of the tube with respect to the top/access end.</p> <p>To calculate the absolute position values for the A direction, use the Mean A readings at each depth and starting at one end, add one to the next. This can be started from the top or the bottom of the survey, depending on the information required.</p>

	<p>The position of the tube at a particular depth is represented by the accumulation of the Deviations at that depth.</p> <p>To calculate the total deviation from top to bottom use the following equation:</p> <p style="text-align: center;">Tot. Dev. = (MD A@0.5 + MD A@1.0 + MDA@1.5....+ MD A@Btm.)</p>
<p>Incremental Displacement</p>	<p>This refers to CHANGES in the inclination of the tube at any particular depth. To calculate the Incremental Displacement, it is necessary to compare the Mean Deviation (Current Data) values with the Mean Deviation (Base Data) values.</p> <p>The Incremental Displacement at any depth is calculated using the following equation (where '0.5' is the selected depth).</p> <p style="text-align: center;">Inc Disp(0.5m) = MDev(0.5) - MDev(Base) (0.5)</p>
<p>Cumulative Displacement</p>	<p>These values are probably the most valuable in any monitoring exercise. They are simply the accumulation of the CHANGES, normally from the base of the tube, up to the top, that represents MOVEMENT of the tube along its length.</p> <p>To calculate the Cumulative Displacement values simply add the Incremental Displacement at the base/far end of the borehole to Incremental Displacement at the next depth upwards, and continue to the top.</p> <p>When plotted with zero at the access end of the graph, the 'Y' axis represents the Base Data file and the plotted values indicate the magnitude of the changes (profile of change).</p>

10.3. Temperature Considerations

Geosense® has carried out significant research into temperature effects on the Probe and its electronics and has found that the thermal effects are very small. However, at the beginning of a survey it is strongly recommended that the temperatures in the probe be allowed to 'normalise', (referred to as the stabilising period) thereby removing temperature gradients within the MEMS circuitry.

Where the probe is used in an inclinometer access tube in a borehole or other subsurface structure, there is usually little variation in temperature over the length of borehole, so thermal effects will be small and corrections will not be necessary.

However, if the probe is subjected to rapid temperature changes, the readings may be affected. Thermal influences are complex. The effect of temperature changes on the MEMS sensor are generally insignificant, but this relates purely to the 'sensor' on the circuit board, inside the probe. Effects on the body of the probe, together with the structure into (onto) which the tubing is installed, will be very complex and difficult to quantify. Consequently, reliable compensation for such changes would be unreliable, so are not considered of value.

11. MAINTENANCE

11.1. Lubrication and Cleaning

The **Geosense**® MEMS Digital Inclinometer is a low maintenance device. With careful use, routine inspections and a small amount of maintenance, it will provide reliable data over a long period.

Upon completion of a monitoring exercise it is strongly recommended that the probe and cable be wiped down to remove moisture and detritus. The connector caps should be fitted whenever the connector is separated. Do not store a wet cloth with the probe in the hard case. Connectors should always be dry and free from dirt before being stored for any periods, as trapped moisture may cause corrosion.

The probe wheels include sealed bearings so cannot be lubricated. However, the wheel carriage spindles should be occasionally lubricated with a light machine oil, to maintain free movement and reduce wear.

The cable connector includes a double 'O' ring sealing system. The 'O' rings should be wiped clean and lubricated with a small amount of Silicon Grease to maintain ease of connection. Contact Geosense for information on how to service the connectors should they become dirty. A dirty connection will impede the function of the system, it is important to keep all connectors clean and free from debris at all times.

Batteries in the Reel and the ASD should be charged regularly to prevent deterioration and maintain their capacity. Only approved chargers should be used.

General Inspections should include the following:

Probe Wheels: Do they move freely and is there any wear in the bearings?

Probe Wheel Carriages: Do they move freely?

Probe Connector: Is the connector clean, free from detritus?
Are the pins straight and clear?
Are the seals in good condition and lightly lubricated with silicone grease?

ASD: Is it dry and are the ports clear of foreign materials?

Cable: Is the cable twist and 'kink' free?
Are there cuts or gouges in the sleeve?

11.2. Storage

Store a dry equipment, in dry cases, in a dry location. (Dry the cloth prior to storing it in the case). The cable connectors should be dried, and caps fitted to protect the pins. Do not fit caps if any water is present as this will cause the connectors to corrode during storage.

11.3. Calibration

All MEMS Portable Inclinometer probes are calibrated at manufacture prior to shipping, with all calibration factors stored internally on the board containing the MEMS sensors. This allows for the unit to provide accurate survey data directly without the need for compensation using calibration factors by the user.

Normal calibration periods are specified at 12-month intervals for probes under light use. For probes under heavy use or that are transported frequently, it may be advisable to increase the frequency of calibrations to ensure the sensors remain within the calibrated tolerances.

It is strongly recommended that any probe that has received a significant shock or vibration, or any damage to the wheel sets, is recalibrated before next use.

12. TROUBLESHOOTING

The below tables represent potential issues and their remedies.

12.1. Probe

Table 6: Probe Troubleshooting

Fault	Possible Cause	Remedy
Difficulty connecting cable		
	Keyways are not aligned Lack of lubrication	Align keyways
	Damaged/bent pins	Return to Geosense for repair
	Dirt/debris	Clean with fresh water and remove all contaminants, then dry
	Threaded collars cross threaded	Do not force threaded parts together, undo and restart thread
Wheelset does not return to fully extended position		
	Presence of dirt / lack of lubrication	Clean with fresh water and dry, then lubricate with light machine oil. If problem persists, replace wheel sets*
Wheels do not turn freely		
	Presence of dirt / lack of lubrication within bearings	Clean with fresh water and dry, then lubricate with light machine oil. If problem persists, replace wheel sets*

12.2. ASD Readout

Table 7: ASD Readout Troubleshooting

Fault	Possible Cause	Remedy
ASD will not turn on		
	Flat battery	Charge battery
	Faulty charger	Try new charger and cable / check outlet is powered
	Faulty battery	Replace battery
The ASD cannot find the reel or finds but cannot connect		
	Reel not turned on	Power the reel on
	Bluetooth is not enabled	Enable Bluetooth on the ASD
	Incorrect connection sequence	ALWAYS use the IncloPRO app to initiate the Bluetooth connection, NOT the phone Bluetooth options
	Interference from other paired Bluetooth devices	Restart reel and ASD and power off other Bluetooth items such as speakers that are linked to the same ASD
	Bluetooth fails to connect despite using the app	Return to Geosense for inspection
The ASD freezes after extended periods of use		
	Bluetooth connection	Power cycle the reel and reconnect using the app to continue monitoring
	Power saving settings	Make sure there are no power saving options enabled in the ASD settings
Fluctuating readings		
	Faulty signal from probe	<p>Check probe connection</p> <p>Check cable for damage</p> <p>Check Bluetooth connection</p> <p>Check ASD settings</p> <p>Change from AUTO to MANUAL mode to record data</p>

	Site conditions	Make sure the casing is still and there are no sources of movement
	Damage to probe	Make sure no damage has occurred to the probe and that it has not been dropped to the base of the hole or incurred any shocks
<i>*if the wheel sets are replaced the probe should be recalibrated</i>		

12.3. Reel and Cable

Table 8: Reel and Cable Troubleshooting

Fault	Possible Cause	Remedy
Reel will not turn on		
	Flat battery	Charge battery and check charger is functioning
	Fault with battery	Replace battery – refer to Geosense support
Cable becomes kinked/twisted		
	Allowing probe to freefall or incorrect deployment/recovery and storage	Replace cable Do not allow probe to freefall

13. SPARE PARTS

Under normal use spare parts are not generally required for **Geosense®** Inclinometer Systems.

However, the following items are available. It is strongly recommended that replacement service components be fitted by **Geosense®** or their qualified representatives:

- 1) Wheel and Carriage sets, including pins and springs
- 2) Batteries and Chargers - Reel & ASD
- 3) Cable support
- 4) Connector caps

Contact **Geosense®** for more details and Service / Calibration options.

14. RETURN OF GOODS

14.1. Returns Procedure

Geosense products are built to the highest quality and workmanship, however if the goods are needed to be returned for either service/repair or warranty, the customer will need to submit a returns request on our website:

<https://www.geosense.co.uk/returns/>

Once you have completed and submitted the online form you will receive a RAN number and a PDF copy of the form will be emailed to the provided email address and to our support team.

Please send back the product to the following address with the RAN Number written on the side of the box.

Geosense Ltd
Nova House
Rougham Ind Est
Rougham
Bury St Edmunds
Suffolk
IP30 9ND

Returned delivery is payable by the customer, as are all inspection charges until a time as a warranty claim has been accepted at which point inspection charges will be credited.

iii. Chargeable Service or Repairs

Inspection & Estimate

It is the policy of **Geosense®** that an estimate is provided to the customer prior to any repair being carried out. A set fee for inspecting the equipment and providing an estimate is also chargeable. Inspection or repairs will not be undertaken without formal order coverage.

iv. Warranty Claim

(See Limited Warranty Conditions – section 15)

This covers defects which arise as a result of a failure in design or manufacturing. It is a condition of the warranty that the **MEMS Digital Inclinometer** must be handled and used in accordance with the manufacturer's instructions and has not been subjected to misuse.

In order to make a warranty claim, contact **Geosense®** and request a **Returned Equipment Report Form QF034**. Tick the warranty claim box and return the form with

the goods as detailed above. You will then be contacted and informed whether your warranty claim has been validated.

14.2. Packaging and Carriage

All used goods shipped to the factory **must** be sealed inside a clean plastic bag and packed in a suitable carton. If the original packaging is not available, **Geosense®** should be contacted for advice. **Geosense®** will not be responsible for damage resulting from inadequate returns packaging or contamination, under any circumstances.

14.3. Transport & Storage

All goods should be adequately packaged to prevent damage in transit or intermediate storage.

15. LIMITED WARRANTY

The manufacturer, (**Geosense Ltd**), warrants the **MEMS Digital Portable Inclinometer** manufactured by it, under normal use and service, to be free from defects in material and workmanship under the following terms and conditions:

Sufficient site data has been provided to **Geosense®** by the purchaser as regards the nature of the installation to allow **Geosense®** to select the correct type and range of **MEMS Digital Inclinometer** and other component parts.

The **MEMS Digital Portable Inclinometer** equipment shall be installed in accordance with the manufacturer's recommendations.

The equipment is warranted for 2 years from the date of shipment from the manufacturer to the purchaser.

The warranty is limited to replacement of part or parts which are determined to be defective upon inspection at the factory. Shipment of defective part or parts to the factory shall be at the expense of the Purchaser. Return shipment of repaired / replaced part or parts covered by this warranty shall be at the expense of the Manufacturer.

Unauthorised alteration and/or repair by anyone which, causes failure of the unit or associated components will void this **LIMITED WARRANTY** in its entirety.

The Purchaser warrants through the purchase of the MEMS Digital Inclinometer equipment that he is familiar with the equipment and its proper use. In no event shall the manufacturer be liable for any injury, loss or damage, direct or consequential, special, incidental, indirect or punitive, arising out of the use of or inability to use the equipment sold to the Purchaser by the Manufacturer.

The Purchaser assumes all risks and liability whatsoever in connection with the **MEMS Digital Portable Inclinometer** equipment from the time of delivery to Purchaser



HEAD OFFICE

Nova House
Rougham Industrial Estate
Rougham, Bury St Edmunds
Suffolk IP30 9ND
England

+44 (0)1359 270457
sales@geosense.com
support@geosense.com

NORTH AMERICA OFFICE

15 West 38th Street
Suite 632
New York
NY 10018

+1 518-920-3483
sales@geosense.com
support@geosense.com

www.geosense.com