

NOTE: This application guide is intended only to give an overview of the several types of VW strain gauges including where and why they are used, how they are typically installed and how data is obtained from them. Please note it is not a definitive guide.

APPLICATION GUIDE - VW STRAIN GAUGES

1.0 General description

Vibrating wire strain gauges are available in several different types to suit individual applications as follows:-



Embedment type

Designed for direct embedment in concrete.

Deformation within the concrete will cause the two end blocks to move relative to each other. The tension in the wire between the blocks will change accordingly thus altering the resonant frequency of the wire.

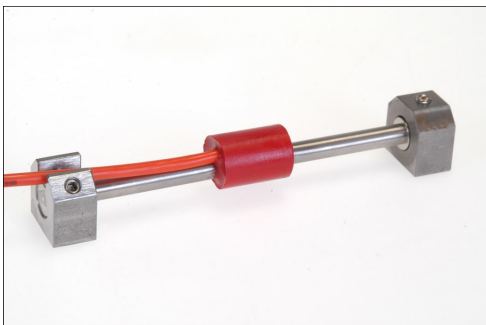

Surface mount (arc weldable) type

Designed for the long term monitoring of steel or concrete structures. Gauges may be attached to steel structures by arc welding or, using alternative end blocks, bonded or grouted into concrete.



Sister bar/re-bar strain meter

A sister bar is typically either a 12mm or 16mm version of the same thing but installed in the cage such that it is not fixed in such a way as it will measure the strain in the reinforcement bar but in such a way that it will measure the strain in the concrete.

The rebar strain meters are intended to be welded into the reinforcement cage to take the place of a piece of reinforcement of equal size. The rebar strain meter will now measure the strain in the reinforcement cage by becoming a load carrying part of the structure.

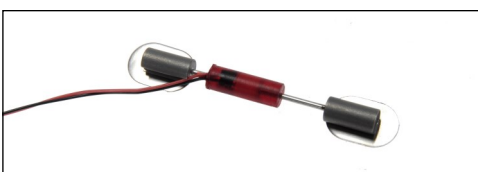

Spot weld type

Designed primarily to measure strains on the surface of steel structures but may also be used on other types of material.

The gauge consists of two end blocks with a tensioned steel wire between them. The end blocks are attached to stainless steel tabs which may be attached to steel structures by spot welding or, using

2.0 Principle of operation

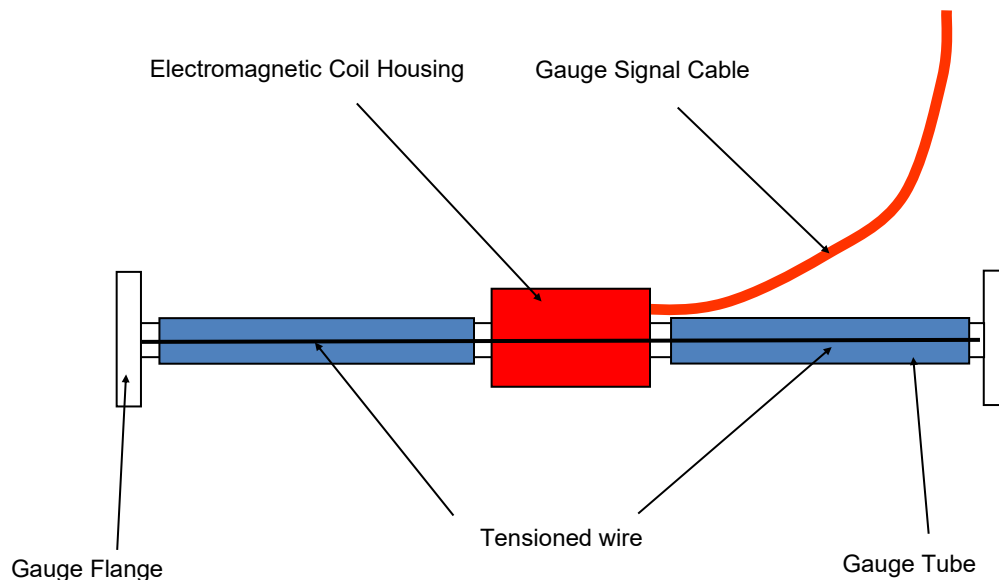

Vibrating wire strain gauges consist of a tensioned steel wire anchored at both ends into flanges. The wire is enclosed in a stainless steel tube. Electromagnetic coils are located within the body close to the axis of the wire. When a brief voltage excitation, or swept frequency excitation is applied to the coils, a magnetic field is induced causing the wire to oscillate at its' resonant frequency. The wire continues to oscillate for a short period through the 'field' of the permanent magnet, thus generating an alternating current (sinusoidal) output. Illustrated above is an embedment type gauge.

The frequency of this current output is detected and processed by a vibrating wire readout unit, or by a data logger equipped with a vibrating wire interface, where it can be converted into 'Engineering' units of Strain.

Forces within the structural element onto, or in, which the gauge is fixed, cause the length of the gauge to change. This causes a change in the tension of the wire within the gauge. It is the tension in the wire that produces the value that can be converted to strain.

A change in length of the wire changes the tension of the wire which results in a change in resonant frequency of oscillation of the wire. The change in the square of frequency of oscillation is directly proportional to the change in strain in the structural element.

Gauge factor

A gauge factor is the equivalent of the strain gauges calibration factor and is required to convert the output of the gauge into the micro strain readings required.

VW gauges get their batch gauge factor from the batch of gauges they come from. A selection of gauges from each individual batches are taken and a calibration is then performed on them, taking readings at set intervals of micro strain across the gauges full range. The average reading at each interval is then plotted. A best fit straight line is then applied to the data and from this analysis the gauge factor is derived. This factor is then given as the factor for each gauge from this batch. Gauge factors are supplied with standard vibrating wire strain gauges.

Calibration

Surface Mount Strain Gauges are available with an individual calibration.

3.0 Typical applications

The following table lists the typical applications, the elements that are monitored and the parameter which the strain gauge is actually measuring.

APPLICATIONS	ELEMENT	MEASURAND	COMPUTATION
Concrete Dams	RCC	Strain	Load
	Mass concrete	Strain	Load
	Arch	Strain	Load + bending
Retaining/Diaphragm Walls	Cage	Strain	Bending
Piles	Concrete (bored)	Strain	Load + bending
	Concrete (precast/driven)	Strain	Load + bending
	Steel H pile	Strain	Load + bending
	Steel Tubular	Strain	Load + bending
	Sheet	Strain	Load + bending
Excavations	Struts & beams	Strain	Load + bending
	Slabs	Strain	Load + bending
Bridges	Box girders	Strain	Load + bending
	Suspension bars	Strain	Load + bending
Tunnel	Lining	Strain	Load
Beams & columns	Concrete	Strain	Load + bending
	Steel	Strain	Load + bending
Anchors / Ties	Bar	Strain	Load
	Strands	Strain	Load

3.0 Typical applications contd...

Rock and Soil Anchors

Strain Gauges can be used on soil and rock anchors (strand) to monitor any gain or loss of tension in the strands.

The strain gauges would be fixed to clamps mounted onto the anchor strand.

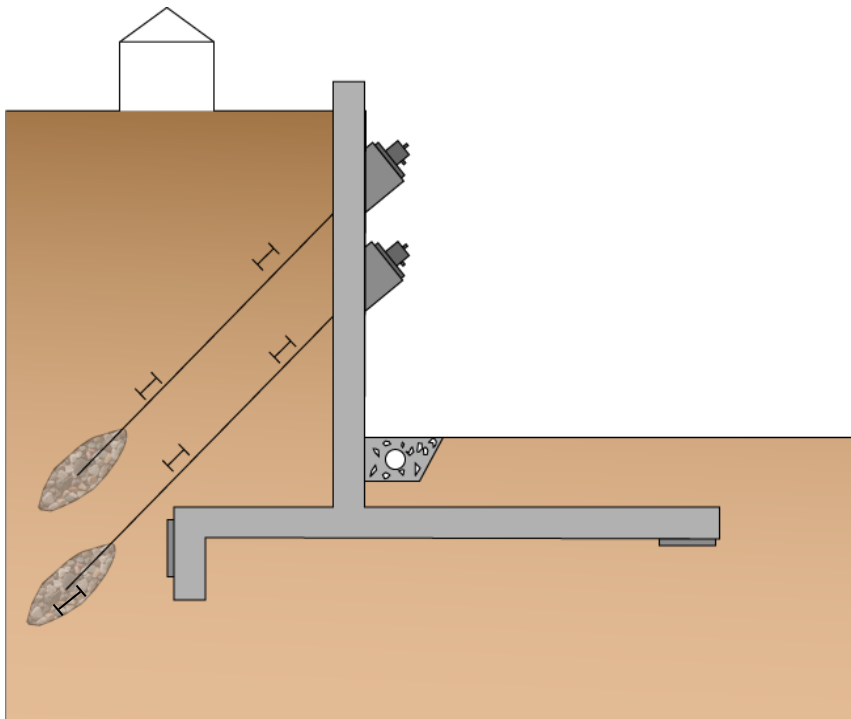

Parameters & where we monitor them?

De-bonded length of the anchor

Total anchor load

Within the bonded length of the anchor

Transfer of load to the bonded length

Why do we monitor these parameters?

To measure the load transfer from the structure to the anchor

To measure transfer of the load within the anchor along the bond length

3.0 Typical applications contd...

Sheet Pile / Diaphragm Walls

Strain gauges fixed to the surface or embedded in a structural retaining wall can be used to measure bending of the wall under load.

Where props are used strain gauges are utilised to determine both its bending and load on it.

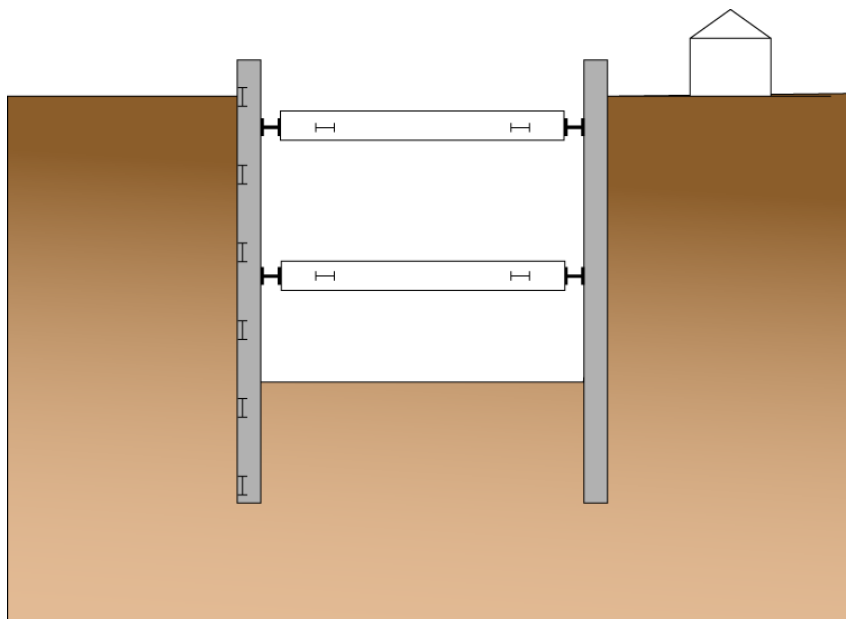

Parameters & where we monitor them?

On or within the structure of the wall

Bending

On or within the structure of the prop

Bending and loading

Why do we monitor these parameters?

To check the integrity of the retaining structure and effectiveness of the propping

To check the integrity of the prop(s) and magnitude of axial loading

Key Note:

Structural elements and the instruments monitoring them will be effected by temperature changes. It is therefore imperative that temperature be recorded together with strain and considered during data interpretation

3.0 Typical applications contd...

Jetties & reinforced earth walls

For Jetties, reinforced earth walls are structures requiring “Tie-bars” strain gauges can be used to determine the load on tendons and/or “Tie-bars”

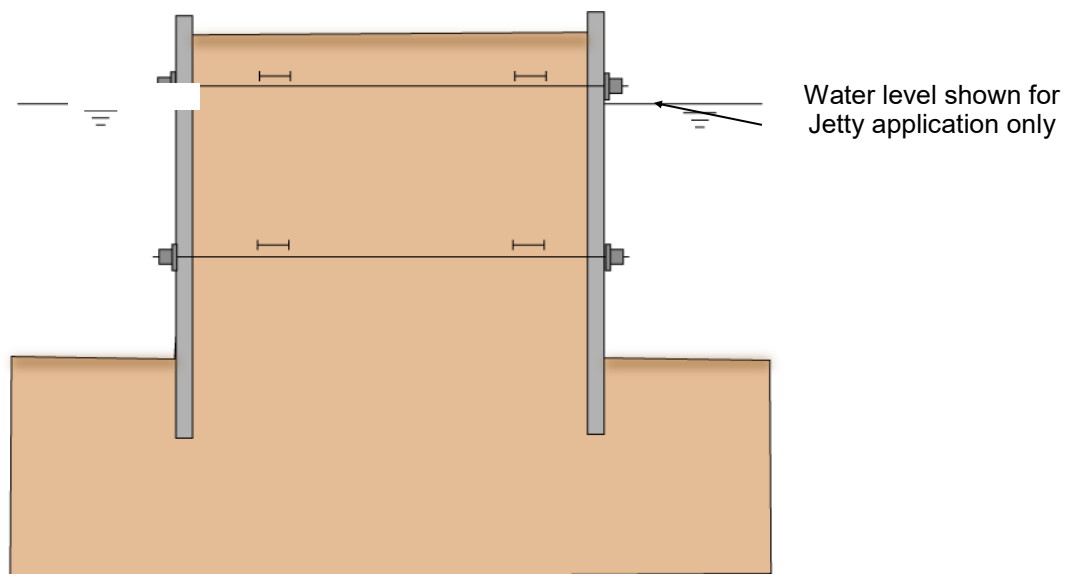

Parameters & where we monitor them?

On or within the structure of the wall

Tendons and/or “Tie-bars”

Why do we monitor these parameters?

To measure the load in the tendons or “Tie-bars” to confirm their performance is within design limits

3.0 Typical applications contd...

Pile Load Testing

Strain gauges can be used in both vertical and lateral pile testing to determine both bending and load distribution for verification of pile design

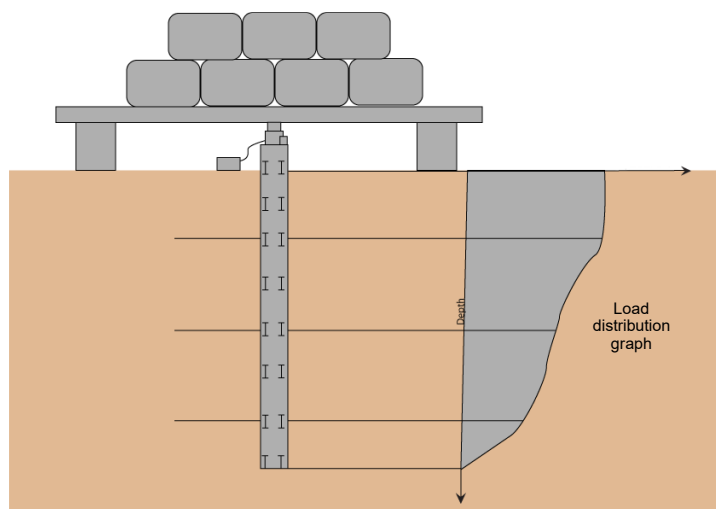

Parameters & where we monitor them?

Key elevations within the pile

Strain changes as a result of loading or unloading

Why do we monitor these parameters?

Monitoring distribution of load in the pile

Design verification

Key Note:

There are two main products for measuring concrete strain, the embedment gauge or the sister bar. Both could be used in this application

3.0 Typical applications contd...

Concrete elevated road/bridge decks

VW strain gauges are often utilised for long term structural health monitoring of elevated roads and/or bridge decks.

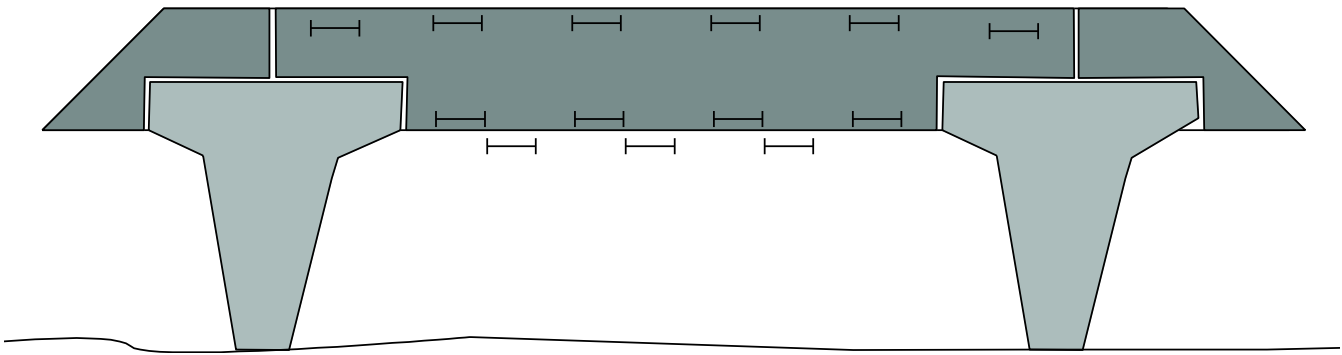

Parameters & where we monitor them?

Within the bridge deck (embedded)

Load and bending

Why do we monitor these parameters?

To verify structural integrity and safe loading

On the bridge deck (surface mounted)

Key Notes:

Ideally the strain gauges would be installed during construction of the bridge deck
 Where post construction monitoring is required surface mounted gauges would be used
 Vibrating wire strain gauges are not generally used for monitoring of dynamic loads

4.0 Installation

There are a number of good working practices which should be adopted when installing strain gauges as follows:-

General considerations

- Strain gauges should be handled with care avoiding bending or dropping them
- Strain gauges should be orientated parallel to the axis that is loaded
- To measure axial load an array of gauges should be installed around the axis of bending
- All equipment should be stored in an environment that is protected from direct sunlight
- Identify the locations where strain gauges will best reflect changes in the parameters to be measured
- Label gauges and cables clearly. Colour coded tapes are commonly used for instrument identification and to mark installation location

Installation of embedment strain gauges

- Gauges are typically mounted on short pieces of re-bar (mounting bars) that are fixed onto reinforcement bars at 90° to the gauge orientation
- Attach the mounting bars to the reinforcement bars using cable ties or tie wire
- Wrap the mounting bars with masking tape at the position of the gauge mounting
- Following installation of the gauge, route the cable to a convenient location

Installation of surface mounted strain gauges

- Select appropriate mounting blocks for the surface to be instrumented e.g. arc weldable, bonded, grouted
- Always use the specific installation tools when attaching the mounting blocks
- Always insert the end of the gauge without the groove into the full mounting block
- Always tension the gauge in accordance with the procedure detailed in the installation manual
- Suitable protective covers against damage and/or thermal effects should be fitted

Installation of spot welded strain gauges

- Surfaces onto which the gauges are to be mounted should always be prepared by grinding and cleaning
- Always use a suitable spot welder to fix one end of the gauge in place
- Always use a purpose built tensioning jig to avoid damage to the gauge
- Always tension the gauge in accordance with the procedure detailed in the installation manual

Installation of sister bars

- Gauges should be mounted parallel to the reinforcement bars
- Attach using cable ties or tie wire
- Following installation of the gauge, route the cable to a convenient location

5.0 Reading strain gauges

Interrogation of vibrating wire strain gauges can be carried out using hand held readouts and/or automatic data acquisition systems (data loggers).

5.1 Signal output

The signal generated by a vibrating wire strain gauge is a frequency. A specialist vibrating wire readout or data logger is used to excite and measure the response of the sensor. The measurement of the response is displayed by the readout in the following formats:-

- **Frequency** - the unit of which is Hertz (Hz)
- **Linear Digits (B unit)**
The frequency output from VW sensors is not proportional to the applied change in length of the wire. In order to overcome the problem of a linear conversion described the frequency value can be squared, thereby rendering it linear, but quite large. To reduce its size, it is often divided by 1000 (or multiplied by 10^{-3}). The expression Hz²/1000 (or Hz² x 10^{-3}) is the most commonly adopted as a 'linear' digital output often referred to as B Units.
- **Period Units (P)** Some readout devices utilise the 'counter' function available in many common integrated circuits.

Period Units represent the time taken for the wire to vibrate over one full oscillation, expressed in seconds. Due to the very small size of the number generated most equipment manufacturers display the unit multiplied by either 1000 (10^3) or 10000000 (10^7).

The relationship between Period units and Frequency units is expressed as

$$P = \frac{1}{\text{Frequency}}$$

5.2 Signal conversion

To enable conversion from the raw data (in the units described above) into engineering units such as micro-strain an instrument requires a Calibration Factor (sometimes called 'Gauge Factor'). The value of the calibration factor will vary depending upon the engineering units into which the raw data is to be converted. Some instruments have "Batch" calibration factors and others are calibrated to generate an individual calibration factor.

The engineering unit typically associated with vibrating wire strain gauges is micro-strain (= strain x 10^{-6}).

5.0 Reading strain gauges contd...

5.2 Signal conversion contd...

Converting from a frequency reading in Hz to micro-strain

Use the following equation to convert a reading in Hz to micro-strain ($\mu\epsilon$):

$$\mu\epsilon = (F^2 / 1000) \times \text{Gauge-Factor} \times \text{Batch-Factor}$$

Where:

$\mu\epsilon$ = micro-strain

F is a reading in Hz.

Gauge-Factor

Batch-Factor (if applicable)

Calculating a change (Δ) in micro-strain

Change in strain is calculated by subtracting the initial strain from the current strain:

$$\text{Change } (\Delta)\mu\epsilon = \mu\epsilon_{\text{current}} - \mu\epsilon_{\text{initial}}$$

or

$$\Delta\mu\epsilon = (F^2 / 1000_{\text{current}} - F^2 / 1000_{\text{initial}}) \times \text{Gauge-Factor} \times \text{Batch-Factor}$$

Where:

$\mu\epsilon$ = micro-strain

$\Delta\mu\epsilon$ = change in micro-strain

F is a reading in Hz.

Gauge-Factor

Batch-Factor (if applicable)

To check whether the gauge is in Tension or Compression:

Positive $\Delta\mu\epsilon$ indicates tensile strain.

Negative $\Delta\mu\epsilon$ indicates compressive strain.

5.3 Gauge factor

A gauge factor is the equivalent of the strain gauges calibration factor and this term can be applied across many different types of strain gauges from Foil gauges to VW gauges. For all Geosense gauges and those of other manufacturers a gauge factor is required whether it is individual or otherwise, for without this factor the readings of the strain gauge are no use. The gauge factor is used to convert the output of the gauge into the micro strain.

Geosense VW gauges get their batch gauge factor from the batch of gauges they come from. A selection of gauges from each individual batches are taken and a calibration is then performed on them, taking readings at set intervals of micro strain across the gauges full range. Once we have this set of values they average reading at each interval is plotted. A best fit straight line is then applied to the data, it is from this analysis the gauge factor is derived. This factor is then given as the factor for each gauge from this batch.

5.0 Reading strain gauges contd...

5.4 Hand held readouts

There are several types of handheld readouts available most of which, are able to read any type of vibrating wire instrument and options include:-

- Direct display - readings need to be manually recorded
- Data storage - readings can be stored for later downloading
- Facility to convert to engineering units - calibration factors and zero values are entered and stored on the unit allowing the conversion to be performed.

5.5 Automatic data acquisition systems

A system designed to regularly record data from instruments independent of operator input, often used in remote environments. A data logger controls and logs the sensor readings and can respond to pre-set alarm trigger levels through on-board software.

Typical components could include:-

- **Central processing unit (CPU)** – to which all the components are linked
- **Vibrating wire interface**
A vibrating wire interface is used to excite VW sensors and on measuring the response performs a Fourier transform which converts the signal frequency into a digital signal e.g. RS 232 which can be transferred to a CPU
- **Multiplexers:** A relay mechanism controlled by the CPU to switch between multiple sensors so that they can be monitored by a single CPU
- **Power Supplies:** A power supply provides regulated power to the logger and sensors. Power is drawn from a battery that is charged either from an AC supply or a solar panel
- **Communication:** Remote or local connection to the CPU to program or download data including GSM, GPRS, radio and cable
- **Software:** Which allows the user to configure code to control the CPU, interrogate and download stored readings either as raw data or engineering units.



Geosense Ltd

Nova House . Rougham Industrial Estate . Rougham . Bury St Edmunds . Suffolk . IP30 9ND . England .

Tel: +44 (0) 1359 270457 . Fax: +44 (0) 1359 272860 . email: info@geosense.co.uk . www.geosense.co.uk

V1.2 May 2021